

## 5 Description of INTERPANE Products



## 5 Description of INTERPANE Products



Friedensreich Hundertwasser once described the building envelope as a person's "third skin". Glass, an essential part of this "third skin", differs positively from other external building components by being transparent.

In contrast to the opaque components, the roof and walls, glass allows natural daylight and free solar energy to be used. This is what makes glass so attractive.

Optimal daylighting increases living comfort with pleasantly light rooms, and heightens the joy of living and working and thus our sense of well-being.

In addition, solar energy gains reduce the heating energy consumption of buildings.

The window has thus been transformed from an energy waster to an environmentally friendly energy collector.

No wonder that the fascinating material, glass, has been used

widely and generously in residential and commercial buildings, as well as in industrial architecture.

Apart from these unique characteristics of glass, modern standards concerning building science and construction technology must also be met:

- energy saving
- thermal insulation
- environmental conservation
- sound insulation
- solar control
- security
- personal safety
- fire protection
- design and construction
- multi-functionality

This applies all the more, now that modern functional glazing is able to replace opaque external building components such as the roof and walls.

INTERPANE offers suitable functional glazing for practically all architectural requirements.

- 5.1 CE Labelling - European product standards
- 5.2 Integrated management system at INTERPANE
- 5.3 iplus E low-e glazing
- 5.4 iplus E/ipaphon sound-insulating glazing
- 5.5 ipasol solar-control glazing
- 5.6 Conventional insulating glazing
- 5.7 ipasafe safety glass
- 5.8 Practical applications of safety glass
- 5.9 ipadecor - design options for glazing surfaces
5. 10 ipaview CF - intelligent liquid-crystal glazing for controllable privacy
- 5.11 Fire resistance
- 5.12 Insulating glazing as a functional design element

### 5.1 CE Labelling - European product standards

CE stands for "Communautés Européennes" - European Communities. This abbreviation is used e.g. to label building products which conform with the harmonised European product standards.

The CE label is neither a label of origin nor a quality seal. It may only be used to label a product, when the product conforms to the Construction Products Directive. It ensures that the product may be traded throughout the EU without any restrictions. Nevertheless, additional demands may be made on the product due to individual national specifications. In Germany, these are published in the "Bauregelliste" (building regulation list).

The CE label documents the declaration by the manufacturer that the product conforms to the underlying product standard.

Proof of compliance with the Construction Products Directive occurs at different levels. Only two levels are relevant for glazing:

*Level 1:*

Initial testing with in-house monitoring and external inspection - corresponds to the previous German "U-Zeichen".

*Level 3:*

Manufacturer's declaration after initial testing with in-house monitoring - corresponds approximately to the previous German "ÜHP".

The requirements resulting from the Construction Products Directive are formulated in the following product standards.

Product standard	Date of introduction	Level
Basic soda lime silicate glass products (e.g. float glass) EN 572	01.09.2006	3
Insulating glass units EN 1279	01.03.2007	3
Coated glass EN 1096	01.09.2006	3
Thermally toughened soda lime silicate safety glass EN 12150	01.09.2006	3
Heat-strengthened soda lime silicate glass EN 1863	01.09.2006	3
Heat-soaked thermally toughened soda lime silicate safety glass EN 14179	01.03.2007	3
Laminated glass and laminated safety glass EN 14449	01.03.2007	3 or 1

With the introduction of the harmonised European Standards (EN) for glass products, the corresponding national standards (e.g. DIN in Germany) will be replaced.

In general, the new European standards for glass have common features:

- A quality management system is demanded,
- quality criteria are prescribed and
- quality tests are specified.

## 5 Description of INTERPANE Products



What must a manufacturer do so that the CE label can be applied to the company's products?

### *Initial testing*

- Select the products which should be labelled
- Prepare system and product descriptions
- Specify performance characteristics
- Document the specifications of the feedstock products
- Three possibilities exist as proof of the initial testing:
  - a) existing test certificates are adequate (inspection possibly together with a testing institute)
  - b) transfer of initial testing results
  - c) conduction of initial testing in-house or by a recognised testing institute
- Confirm successful initial testing
- Provide application guidelines (e.g. glazing guidelines or handling instructions)



### *Factory Production Control*

The requirements and the documentation of the in-house production control must be described in a quality handbook.

- Name qualified staff for carrying out the in-house production control
- Define organisational structure and responsibilities
- Describe process organisation (control of incoming deliveries, production technology and production sequences)
- Prepare testing plans and audits
- Make testing facilities accessible
- Specify set of measures for deviations
- Document the factory production control when carried out
- Collect conformity declarations of suppliers

When the in-house production control has been established and the initial testing has been passed successfully, it is then possible for

- the conformity certificate to be awarded by the certification agency (for level 1 products)
- the conformity declaration to be made and
- the products to be labelled with CE labels.

The labelling with the CE symbol can be done e.g. directly on the product, on an adhesive label or the delivery note.

The declared properties can be documented in any data format (e.g. table, catalogue, Internet pages). It is sufficient to indicate the access path on the CE label, e.g. CE EN 1279 [www.interpane.net](http://www.interpane.net)

### *Audits and inspections of on-going production*

On-going conformity of the product with the technical specifications is to be monitored by regular quality audits under supervision or by an independent body which does not belong to the production:

- inspection of the factory production control
- inspection of the quality-relevant product characteristics
- inspection of the testing means used
- documentation of the audit testing results

Further reference to CE labelling is included in the individual product chapters.

## 5 Description of INTERPANE Products



### 5.2 Integrated management system at INTERPANE

Quality is becoming increasingly important as a criterion to distinguish between competitors. For this reason, INTERPANE already introduced the higher-level Integrated Management System (IMS) in 2005. It encompasses not only quality aspects but also environmental conservation and safety at work.

INTERPANE's goal is to be a reliable partner for clients and

Quality is the fulfilment of agreed and affirmed quality specifications.

suppliers, and to deliver high-quality products with well-controlled processes completely and punctually.

INTERPANE sees itself as a pacemaker for product and process innovations.

Long-term business relationships which are conceived as partnerships form the foundation for the success of both partners.

Quality management does not mean higher costs but cost minimisation for everyone - above all also for the client.

#### 5.2.1 Quality criteria for insulating glazing

Throughout all the changes in standards and legal boundary conditions, INTERPANE has always attached greatest importance to its own high quality criteria since its inception.

Among other activities, INTERPANE was already actively involved in 1982 in the foundation of the German "Gütegemeinschaft Mehrscheibenisolierverglas (GMI)" (Quality-Control Association for Multiple-Pane Insulating Glazing).

The German "RAL" quality seal is awarded to insulating glazing manufacturers which successfully implement the quality and testing procedure of the GMI in their production.

The objective of GMI was (and still is) to position insulating glass on the market as a reliable, durably functional building product. This was recognised by the German legislative bodies, which included many of the quality criteria and procedures from GMI in the 3rd Thermal Insulation Regulation which was introduced in 1995. This includes external inspection of the insulating glazing manufacturer ("Ü-Zeichen" regulation).

The harmonised European product standards (EN) for insulating glazing now also include the concept of fixed quality characteristics, in-house quality controls and documentation of the test results. These standards thus combine the quality elements which had been developed voluntarily, such as

- quality characteristics
- testing procedures and
- quality management.

However, these systematic and self-consistent sets of standards are accompanied by serious disadvantages:

- on the one hand, the lack of previously obligatory external inspection of insulating glazing manufacture,
- on the other hand, the lack of an integrated quality-control system with regard to the final product, an "installed window".

The insulating glazing manufacturer is still well advised to maintain the proven external inspection of his production. Gradual changes in feedstock materials and production processes are recog-

nised more quickly and certainly if a large number of random samples is taken, e.g. initial moisture content of desiccants, sealants or gas fill.

The insulating glazing standard, EN 1279, offers wide scope for varying interpretation. This leads not only to uncertainty in implementing the standard, but also to "creative interpretation".

The practice of external inspection ensures that the standards are applied appropriately and that the declared product characteristics are indeed achieved; e.g. emissivity of the coating or gas tightness of an insulating glass unit. In addition, the test results from neutral, external quality control can already help to avoid legal conflicts *a priori*.

#### Integrated quality approach

If the final customer's expectation of functional, long-lived and thus durably operating windows is to be met, already the installer of the windows should follow an integrated quality concept. This means that product compo-

## 5 Description of INTERPANE Products



nents can only be fully functional if they are selected and combined correctly.

For this reason, the quality and testing regulations for windows demand the use of quality-controlled insulating glazing, i.e. usually subject to external inspection.

The quality and testing regulations defined by GMI for insulating glazing extend beyond the requirements of EN 1279 by including special requirements on e.g. coated glass panes or the compatibility of sealants.

EN Standard specifications and additional quality-determining characteristics of insulating glazing production.

### EN 1279

- System description
- Product description
- Initial testing
- In-house production control
- Audit tests and inspections
- Conformity declaration
- Declaration of performance characteristics
- CE label

### GMI Quality and Testing Requirements

- External monitoring
- Testing of feedstock products
- Overview list of variants
- Compliance of test samples with system description
- Tolerances for gas fill
- Visual specifications for final product



Significant additional specifications according to GMI:

- Gas fill percentages ( $c_{10}$ ) > 90 % are minimum values, i.e. negative tolerances are not permitted.
- The measured value for the emissivity ( $\epsilon_m$ ) ≤ the declared value  $\epsilon_d + 0.01$ .

### 5.2.2 Product description of INTERPANE insulating glazing according to EN 1279

INTERPANE insulating glazing products consist of two or more glass panes, which are separated from each other by one or more desiccated and hermetically sealed, gas-filled spaces.

To this purpose, the glass panes are separated by the desired gas space width with one or more spacer bars made of aluminium, stainless steel or polymer/metal combinations.

The edge seal for insulating glazing always consists of two sealant stages:

- a primary sealant, consisting of butyl extruded completely around three sides of every spacer bar.

It serves as a barrier to water vapour and gas diffusion, and thus fulfils the main objectives of preventing air moisture from entering and the filling gas from escaping from the unit.

- a secondary sealant (e.g. polysulphide, PU, silicone) applied according to the system description.

This secondary sealant serves two purposes:

1. Permanent attachment of the panes by formation of a chemical bond between the sealant and the glass surfaces around the edge of the panes.
2. Hermetic sealing of the space between the panes in the insulating glass unit, making it airtight or gastight.

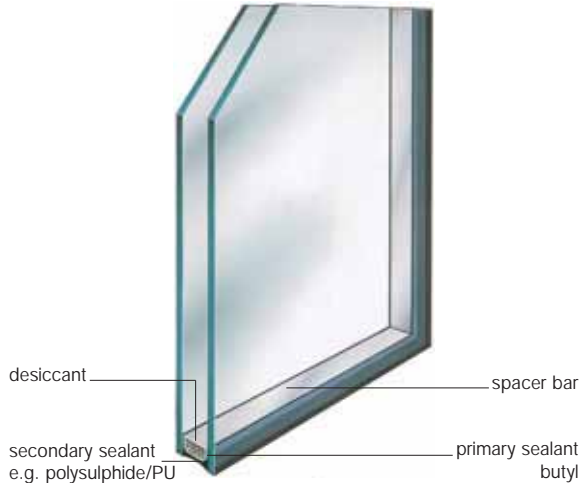

Cross-section through an INTERPANE insulating glass unit

This permanently elastic composite accommodates the mechanical stress caused by pumping, suction, shearing, pressure-related and thermally induced movement.

The gas in the space between the panes is dried by the desiccant which fills the hollow, perforated spacer bar (see Section 4.13).

The desiccant also adsorbs the water vapour which diffuses through the edges into the insulating glass unit during its lifetime.

Depending on the product, the space is filled with ambient air or gases and can contain inserts such as glazing bars.

The following product families are manufactured by INTERPANE in accordance with the description above:

- iplus low-e glazing
- ipasol solar-control glazing
- ipaphon sound-insulating glazing
- ipasafe safety glazing
- INTERPANE conventional insulating glazing

The products of these product families are manufactured in accordance with the system description of EN 1279, Parts 1, 2, 3, 4 and 6.

INTERPANE insulating glazing thus fulfils the expectations on high-quality insulating glazing with a long life expectancy.

The production of INTERPANE insulating glazing is based on the quality criteria presented in Section 5.2.1 and is subject to on-going external inspection and in-house quality monitoring.



# **INTERPANE** *GLASS FOR LIFE*

iplus E, low-e coated glass as a basis for a comprehensive product palette

$U_g$  values down to  $0.5 \text{ W/m}^2\text{K}$   
(according to EN).



### 5.3 iplus E low-e glazing

Since the middle of the 1990's, low-e (low-emissivity) coated, thermally insulating glazing products have evolved to become standard for window and facade installations.

Insulating glazing with  $U_g = 1.1$  W/m<sup>2</sup>K has established itself on the market. The trend toward more energy-efficient buildings is continuing.

The European Energy Performance of Buildings Directive (EPBD) demands an integrated approach in evaluating the energy performance of buildings. In this concept, not only the thermal losses and solar gains but also the light transmittance of the glazing are given high priority.

With its iplus E product family, INTERPANE offers a broad spectrum which can fulfil practically all architectural and functional requirements on a building:

- iplus neutral E, the synonym for neutrally coloured low-e glazing with  $U_g = 1.1$  W/m<sup>2</sup>K
- iplus city E, triple protection for discerning building owners

- iplus 2CE and iplus CE - double-glazed units offering top-class thermal insulation with  $U_g$  down to 1.0 W/m<sup>2</sup>K
- iplus 3E and iplus 3CE - super low-e glazing for lowest-energy and passive buildings
- iplus 3L and iplus 3CL - triple-glazed low-e units with an optimal energy balance

The market and customer expectations on high-quality insulating glazing are continually increasing. This has both ecological and economic reasons, e.g. concerning environmental conservation and energy savings. The stakeholders rightfully demand:

- a complete palette of sophisticated products
- continuous technical improvement of the products with respect to heating energy consumption and air-conditioning
- punctual delivery of high-quality coated glazing also with substrates of thermally toughened glass, heat-strengthened glass and glass laminates

- logistic services for complex building projects

Benefits for clients and the environment already arise from INTERPANE coating equipment and procedures:

- coatings for highest technical demands
- customer-oriented production, logistically optimised for error-free, punctual delivery
- measurement and documentation of the production results
- environmentally friendly production without emission of pollutants or noise

## 5 Description of INTERPANE Products



### Market perspectives

The existing German building stock, with an average annual heating oil consumption of 20 l/m<sup>2</sup>a and some values reaching up to 50 l/m<sup>2</sup>a, can hardly be described as "modern".

There are still approximately 340 million windows in Germany (more than 60 % of all installed windows) which are not equipped with low-e coated, thermally insulating glazing and thus need energy-saving renovation. They do not meet up to ecologically necessary or economically sensible standards, let alone the technologically feasible potential.

These 340 million windows account for approximately 440 million m<sup>2</sup> of outdated glazing.

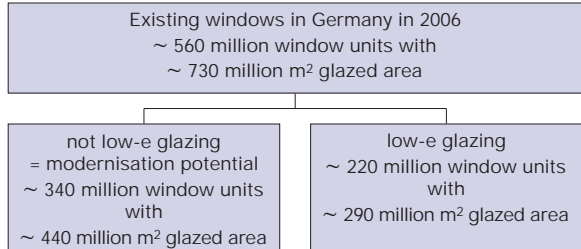

The recent energy price explosion underlines the need to save energy.

The German Federal Government has also recognised this and has initiated correspondingly attractive funding programmes for energy-related building renovation.

These national funding programmes to stimulate improved energy efficiency in the building

stock will act as an example for all of Europe.

With the number of windows throughout Europe estimated to be between 3.5 and 5 thousand million, this results in a gigantic potential for the glazing, window and façade sector.

Let's work on it!



### 5.3.1 Coating technology

At INTERPANE, in-line sputtering in vacuum chambers is used as the coating technology (Fig. 1).

The pressure in the sputtering chamber is reduced to about one millionth bar (app.  $10^{-3}$  mbar). The glass pane is trans-

ported from the input chamber through a transfer chamber to the sputtering chamber, where the coating process actually takes place.

In order to obtain homogeneous coatings, the glass is transpor-

ted under the coating devices at a constant speed.

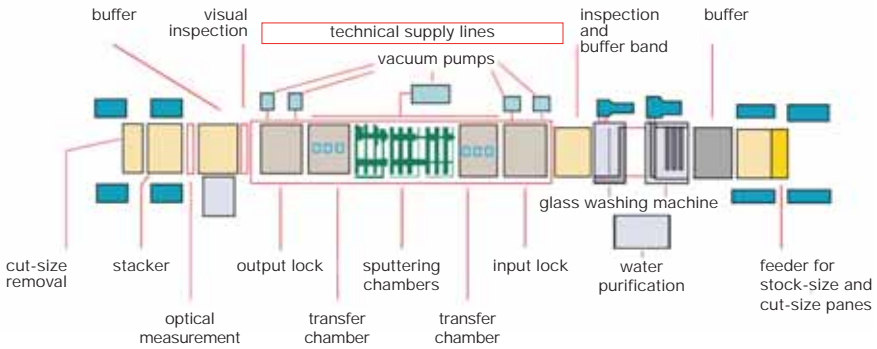

Fig. 1: Schematic diagram of the continuously operating coating line with high-performance sputtering (in-line process).

## 5 Description of INTERPANE Products

The coating procedure itself is shown schematically in Fig. 2: For sputtering, a plasma is created in a vacuum chamber by applying a high voltage between a cathode and an anode. The plasma forms when atoms of the inert gas, argon, are introduced into the chamber and are transformed into heavy, positively charged argon ions by collisions with electrons. The plasma can be recognised by its typical coloured appearance, similar to that in fluorescent tubes. The strong electric field created by the high voltage accelerates the heavy, positively charged argon ions toward the cathode.

A so-called "target", which consists of the coating material (e.g. silver), is mounted on the cathode. The incident high-energy argon ions knock material out of the target, which is then deposited as a thin layer on the glass (Fig. 3).

Oxygen is additionally introduced into the chamber as a reactive gas to form chemical compounds (e.g. bismuth oxide) with the atomised target materials.

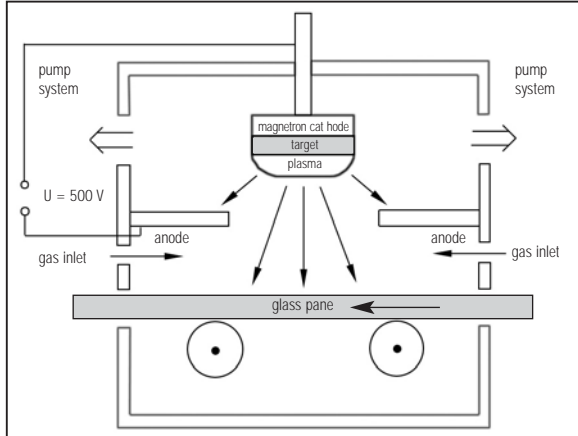

Fig. 2: Schematic cross-section of a cathode chamber to deposit thin films by the magnetron sputtering procedure.

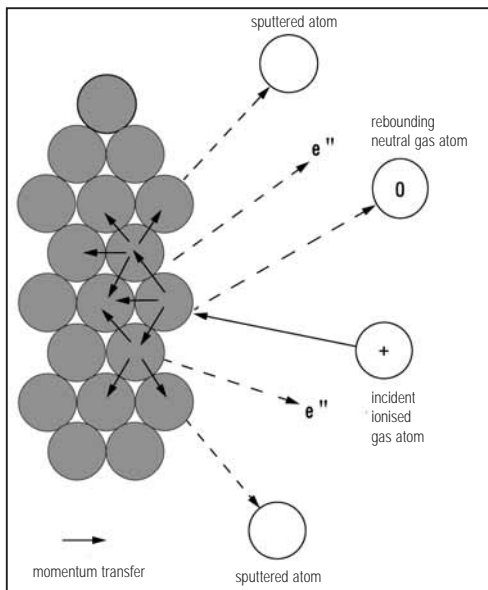

Fig. 3: Surface processes during sputtering.

### 5.3.2 iplus and ipasol basic coated glass

A pane of glass which is coated with an extremely thin, low-emissivity coating is what INTERPANE means by "iplus basic coated glass". It is then further processed into insulating glass units with excellent thermally insulating properties. By contrast, "ipasol basic coated glass" is the semi-finished product for manufacturing highly functional solar-control glazing (see Section 5.5).

INTERPANE has coating plants in Lauenförde, Plattling and Seingbouse in France.

As well as being further processed within INTERPANE, the iplus and ipasol semi-finished products are delivered to INTERPANE's partners for processing into functional insulating glazing. These products are available on the market both under the brand names of "iplus" and "ipasol", as well as company-specific trade names (usually with the descriptor "iplus / ipasol").

A common set of glass-processing guidelines for the INTERPANE production plants and the partners which process the semi-finished glass ensures that the high quality standard is met which is expected for high-performance, functional insulating glazing.

Why is a coating applied?

Single glazing, which was standard until the middle of the 1970's, is responsible for large thermal losses ( $U_g = 5.8 \text{ W/m}^2\text{K}$ ). Double glazing then became more common, with its improved  $U_g$  value of about  $3.0 \text{ W/m}^2\text{K}$ .

It was not until double glazing technology was combined with modern thin-film technology to create transparent coatings on glass that the specific energy losses could be halved yet again.

Colour-neutral, coated insulating glazing was first introduced by INTERPANE to the market at the beginning of the 1980's. A vigorous market campaign, including the distribution of basic coated glass as a semi-finished product, ensured that iplus was soon widely disseminated. Today, thermally insulating glazing (low-e glazing) with a  $U_g$  value of  $1.1 \text{ W/m}^2\text{K}$  is accepted as the state of the art.

With triple glazing,  $U_g$  values down to even  $0.5 \text{ W/m}^2\text{K}$  can be achieved. This means thermal losses that are only a tenth of those for single glazing!

In contrast to metals, which re-radiate about 2 to 10 percent of the absorbed energy, i.e. which have a low emissivity value,  $\epsilon$ , (see Section 4.2), glass does not possess this favourable property. More than 80 percent of absorbed heat is emitted via the glass surface ( $\epsilon = 0.85$ ). In order to combine the transparency of glass with the excellent emission properties of precious metals, thin metal films are deposited onto the glass. These are transparent to sunlight but simultaneously reduce the emissivity of the glass surface very effectively. Extremely thin silver films with a thickness of about  $1/100,000 \text{ mm}$  ( $= 10 \text{ nm}$ ) are optimal.

The structure of low-emissivity and solar-control coatings

Different coating materials are deposited onto glass to produce the INTERPANE thin-film stacks. Films to provide adhesion, thermal functions, cover and protection form a complex system.

The optical properties are achieved by applying the interference principle, which is familiar from anti-reflective coatings on camera and spectacle lenses.

The ipasol solar-control coatings are similar to the others in principle, but have a significantly more complex coating structure.

The desired properties regarding solar and thermal radiation are obtained with additional absorbing and/or reflecting components

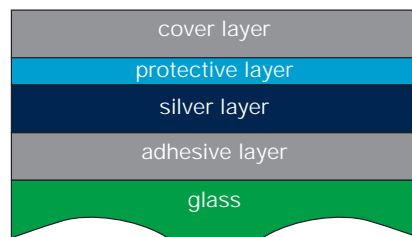

**Example: Structure of a low-e coating on glass**

## 5 Description of INTERPANE Products



### Coated glass for tempering from INTERPANE

As coated glass cannot generally be heat-processed to produce thermally toughened or heat-strengthened glass, the coating must be deposited subsequently onto the thermally toughened or heat-strengthened panes.

As an alternative, INTERPANE delivers coated glass with the product name of iplus ET, which can then be heat-processed by the customer.

This offers logistic advantages: Manufacturers of safety glass, or producers of insulating glass units with their own safety glass production, can deliver their products at short notice if they store the coated glass in their warehouse. Complicated and expensive transport of cut-size panes becomes unnecessary.

iplus ET is optically compatible with iplus E, so is suitable for mixed glazing applications.

### Coated glass dimensions

Both the commercially widespread float glass panes ("jumbos"), with dimensions of 6.00 m x 3.21 m, and stock-size and cut-size panes can be coated. The minimum dimensions for coating are 0.24 m x 0.24 m. Glass with a thickness of up to 19 mm (float glass) and safety glass such as thermally toughened and laminated glass can be coated.

INTERPANE thus offers a comprehensive delivery programme.

### Quality-controlled production

The coating homogeneity plays a special role for large-area production of these low-e and solar-control coatings, iplus and ipasol. Inhomogeneity is disturbingly evident as colour effects both in external reflection by and transmission through a glazing unit.

INTERPANE coating plants are consistently designed to achieve high-quality, homogeneous coating.

On-line technology to measure the colour in reflection and transmission is part of the process-control and quality-control technology - and the measurements are made not only at one position, but distributed over nine measurement points of the jumbo glass panes (see graphs on next page).

The measurement results are saved electronically together with the equipment settings: They can be accessed at any time and correlated with each delivery, pane for pane.

Comparison with benchmarks is also made electronically. Colour defects are recognised automatically and faulty coatings are sorted out.

### CE label

Since 1.9.2006, the CE conformity label has been required for coated glass.

Basic coated glass must conform to the European product standard, EN 1096. It specifies a manufacturer's declaration about conformity after initial testing of the product (Level 3).

Beyond this, INTERPANE coating companies voluntarily subject their plants to external monitoring by a notified body. Although the standard for emissivity specifies  $\epsilon_m \leq \epsilon_d + 0.02$ , the measured value of emissivity at INTERPANE  $\epsilon_m$  satisfies a smaller tolerance, namely  $\leq$  the declared value  $\epsilon_d + 0.01$ .

## 5 Description of INTERPANE Products



The measurement protocol shows that measurements were made at nine positions of the coated float glass pane. Comparison is made with benchmark curves.

CCC

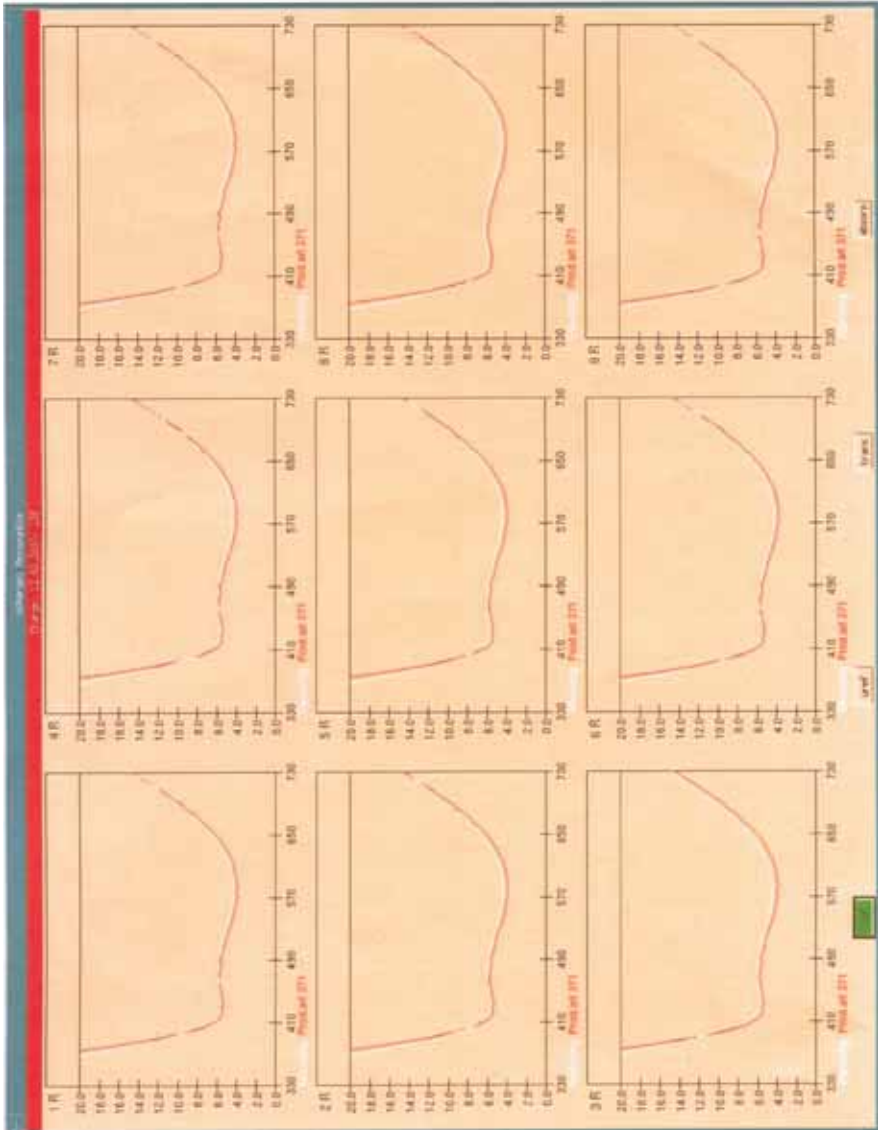

### 5.3.3 iplus neutral E coated insulating glazing

Thermal principle of operation

The heat flux through insulating glazing is determined by the following components:

- radiation exchange between the panes according to the emissivity of the pane surfaces for thermal radiation
- heat conduction by the gas in the gas-filled space
- convection of the gas in the gas-filled space

In conventional, uncoated double glazing, about two-thirds of the heat flux is caused by the radiation exchange between the panes due to the high emissivity of the glass surface. Only one-third is caused by conduction and convection of the air in the space between the panes.

The low-emissivity coating reduces the emissivity from  $\epsilon_d \approx 0.89$  for uncoated glass to e.g.  $\epsilon_d \approx 0.03$  for iplus E. Thus, the radiation exchange is suppressed almost completely. The heat flux due to conduction and convection in the gas-filled space remains unchanged.

Thus, a low-emissivity coating based on silver, such as is used in iplus E, reduces the  $U_g$  value of double glazing from approximately  $3 \text{ W/m}^2\text{K}$  to  $1.4 \text{ W/m}^2\text{K}$ .

If, in addition, the air in the space between the panes is replaced by an inert gas such as argon, which has a lower thermal conductivity, the  $U_g$  falls again by  $0.3 \text{ W/m}^2\text{K}$  to  $1.1 \text{ W/m}^2\text{K}$ .

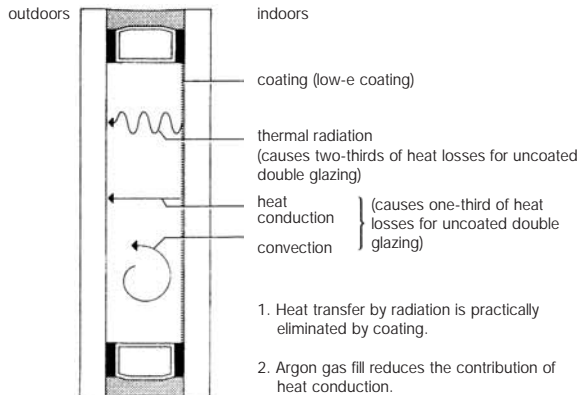

Heat-transfer processes through insulating glazing

#### Coated insulating glazing

The following graph plots the  $U_g$  value as a function of the width of the gas-filled space and the type of gas, using iplus E as an example.

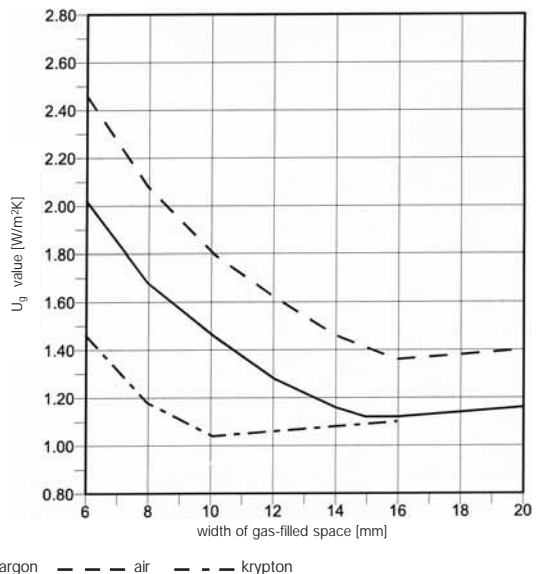

Calculation according to EN 673: 90 % gas fill.

## 5 Description of INTERPANE Products



F22

### Light and radiative properties

The light, solar-radiation and thermal properties of a glazing unit are decisive.

Light and radiative properties refer to the following fundamental physical processes:

- transmission
- reflection
- absorption

The light (or visible) properties are defined with reference to visible light in the spectral range between 380 nm and 780 nm. Radiative properties refer either to the solar spectrum between 300 nm and 2500 nm or to infrared, thermal radiation with wavelengths up to about 300  $\mu\text{m}$ .

The operation principle for thermally insulating, low-emissivity coatings is as follows:

The coatings act as a filter, which is why they are also called "selective". For short-wavelength radiation, (solar radiation particularly in the visible range), low-emissivity coatings are highly transparent, whereas they are highly reflective for long-wavelength radiation, particularly the infrared spectral range between 3000 nm and 50  $\mu\text{m}$ .

In practice, this means that solar energy (300 nm to 2500 nm) can enter indoor rooms relatively unhindered (solar collector effect). This energy is absorbed by the materials in the room and much of it is emitted as long-wavelength thermal radiation. The functional low-emissivity coating prevents this long-wavelength thermal radiation from leaving the room.

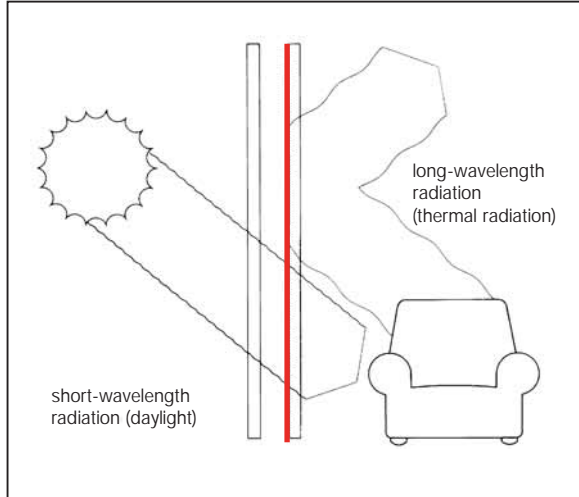

The greenhouse effect - an energy trap

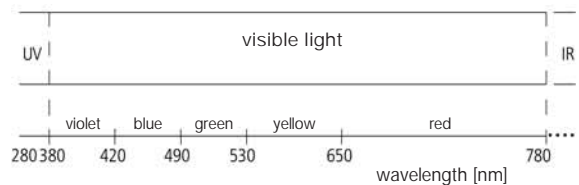

Correlation between wavelength and spectral colours

## 5 Description of INTERPANE Products



### Edge coating removal

A simple process is applied to remove the coating along the edges of the pane,

- to guarantee reliable adhesion of the insulating glazing sealant to the glass,
- to avoid damage to the coating along the edge of the pane due to the natural pumping movement of the insulating glass unit,
- to prevent moisture from penetrating the individual layers (see figure) and
- to prevent corrosion of the silver film due to reaction with water.

### Coating on cut-size panes / coating spillover

When cut-size panes are coated (without masking), the coating can be deposited also onto the sides of the glass pane or even

onto the back surface to a limited extent. This is unavoidable in the production process. We recommend removal of this "spillover" coating already during further processing to make insulating glass units, particularly if these regions are to be used as adhesion surfaces for sealing joints.

### Masking

For structural glazing, the ETAG 002 (European Technical Approval Guideline) specifies adhesion which can bear mechanical loads.

Coated surfaces, including coated glass, must be tested for their functionality as part of an authorisation process.

The adhesion zone must be kept free of coating materials if "soft coatings" have been deposited.

For this reason, INTERPANE uses tape to mask the load-bearing adhesion zone of structural glazing during the coating process.

The INTERPANE coating companies offer cut-size coated glass with customer-specified masking. See also Section 3.8 on Structural Glazing.

### Effect of glazing bars on thermal insulation

Due to the thermal bridge effect of genuine glazing bars (muntins) or incorrectly designed internal glazing bars for insulating glass units, the thermal insulation of windows is often reduced appreciably. The thermal bridges arise due to zones with higher thermal conductivity along the edge of the glass, through the material of genuine glazing bars and by contact between the glass panes and glazing bars inserted into the gas-filled space.

Technically mature glazing bar systems such as the "Swiss Cross" and the "Viennese glazing bar" reduce these problems, as large-area glazing units with (optically) small sections can be achieved. At the same time, the typical worsening of  $U_g$  values and susceptibility of windows with genuine glazing bars to condensation can be reduced (see also Sections 3.3.2 and 5.12.2).

### iplus E improves indoor comfort

With iplus E, it is possible to plan generously glazed areas which meet not only economic and ecological criteria but also aesthetic demands, without wasting energy.

At the same time, the rooms remain comfortable.

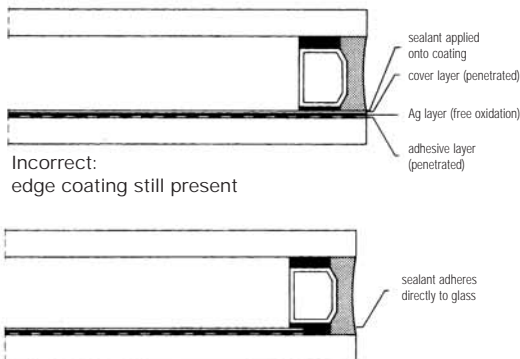

Correct:  
edge coating removed

## 5 Description of INTERPANE Products



In order to achieve indoor comfort, the temperatures of the room air, the indoor window surfaces and the indoor wall surfaces must be as similar as possible. The individual surface temperatures of the enveloping surfaces of a room should thus not differ by more than about 6 K.

For given outdoor meteorological conditions, the indoor pane temperature depends directly on the  $U_g$  value.

The following comfort diagram was developed on the basis of investigations by Bedford and

Liese. With an indoor temperature of + 22 °C, iplus neutral E is already close to causing an "uncomfortably" warm room. If the room temperature is reduced by 2 K, iplus neutral is on the optimum curve.

Experience shows that reducing the indoor temperature by 1 K can save up to 6 % in heating energy.

iplus neutral E prevents too much heat being lost from the human body by radiation and convection. This increases comfort.

Effect of coated, thermally insulating glazing on plant growth

Investigations conducted by Prof. K. Zimmer at the Institute for Ornamental Plants, University of Hanover, demonstrated that a negative effect on plant growth is not to be expected.

Although the light intensity is reduced slightly, the spectral distribution of the light is not changed significantly. This applies also to the ultraviolet component of daylight, so that the light quality is retained and colour rendering is good. At the same time, reduced absorption of radiated energy means that the plants heat up less.

This was also confirmed by scientific investigations by S. Hoffmann in 1998 at the Institute for Technology in Horticulture and Agriculture at the University of Hanover (see also Section 7.6).

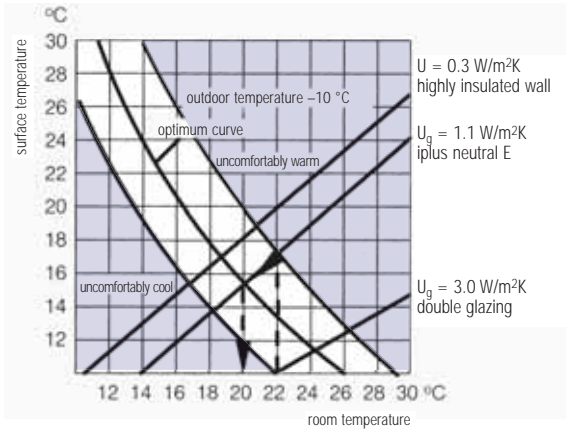

Comfort diagram according to Bedford and Liese

For an outdoor temperature of -10 °C and an indoor temperature of + 21 °C, the indoor pane temperature (surface temperature) is		
for	$U_g$ value	surface temperature
conventional, uncoated double glazing	3.0 W/m <sup>2</sup> K	+ 9 °C
iplus neutral E	1.1 W/m <sup>2</sup> K	+ 17 °C
iplus CE	1.0 W/m <sup>2</sup> K	+ 17 °C
iplus 3CE / iplus 3CL	0.5 W/m <sup>2</sup> K	+ 19 °C
outer wall	0.3 W/m <sup>2</sup> K	+ 20 °C

### 5.3.4 iplus neutral E - the innovative thermally insulating glazing

An iplus neutral E thermally insulating glass unit consists of two glass panes which are separated from each other by a hermetically sealed, gas-filled space.

The two glass panes are kept apart by the desired distance - usually 14 mm or 16 mm - by a spacer which is attached by the well-proven, permanently elastic double sealing system.

The space is filled with an inert gas, and one glass surface is coated with an iplus E film.

The extremely thin film (thickness:  $\approx 0.1 \mu\text{m}$ ) is usually located on the surface of the indoor pane which faces the space (position 3).

However, the coating could also be located on the inner surface of the outdoor pane (position 2), e.g. for aesthetic reasons, without the  $U_g$  value being affected negatively.

iplus neutral E continues to be a standard for colour neutrality among coated insulating glazing.

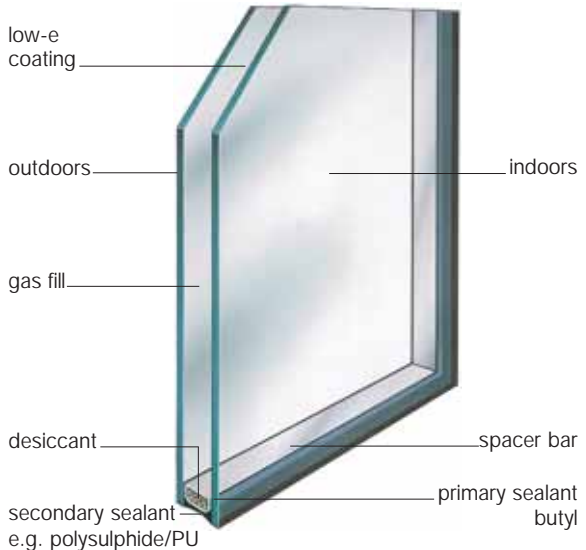

Cross-section through an iplus neutral E insulating glass unit

### Delivery programme for iplus neutral E

#### Technical data: iplus neutral E

product name	configuration outer/ space/inner	U <sub>g</sub> value according to EN 673	rated light and solar-radiation properties according to EN 410			thickness	mass	max. dimensions	max. area	max. ratio of side lengths
			g value	light transmittance	general colour rendering index in transmission					
	mm	W/m <sup>2</sup> K	%	%	–	mm	kgm <sup>2</sup>	cm	m <sup>2</sup>	–
iplus neutral E	4/16/4	1.1	60	80	97	24	20	141 x 240	3.40	1 : 6
iplus neutral E	5/16/6	1.1	59	78	96	27	27	245 / 300	6.00	1 : 10
iplus neutral E	6/16/6	1.1	58	78	96	28	30	250 / 400	8.00	1 : 10
iplus neutral E	4/14/4	1.2	60	80	97	22	20	141 x 240	3.40	1 : 6
iplus neutral E	5/14/6	1.1	59	78	96	25	27	245 / 300	6.00	1 : 10
iplus neutral E	6/14/6	1.1	58	78	96	26	30	250 / 400	8.00	1 : 10
iplus neutral E	4/12/4	1.3	60	80	97	20	20	141 x 240	3.40	1 : 6
iplus neutral E	5/12/6	1.3	59	78	96	23	27	245 / 300	6.00	1 : 10
iplus neutral E	6/12/6	1.3	58	78	96	24	30	250 / 400	8.00	1 : 10

- The customer ordering our products is responsible for ensuring that the glass thickness is dimensioned correctly according to the applicable technical regulations.
- The specified rated values refer to the testing conditions and the application scope of the referenced standard.

### 5.3.5 iplus CE and iplus 2CE -

#### Peak thermal insulation with double glazing

Among new buildings, average energy consumption values of 70 kWh/m<sup>2</sup>a are the standard. The planner has the freedom to decide how this energy target is to be achieved.

The attractive iplus CE and iplus 2CE products present a good option for optimised thermal insulation in windows.

Compared to iplus neutral E, the  $U_g$  value is better by up to 10 percent. With heat transfer coefficients down to 1.0 W/m<sup>2</sup>K according to EN 673, the limits have been reached for what is physically feasible and economically viable with a double-glazed configuration.

The particularly slim iplus CE glazing unit, with its installation thickness of only 18 mm, is ideally suited to replace uncoated double glazing "from yesterday" in window frames which are still functional, improving the energy performance of the whole window.

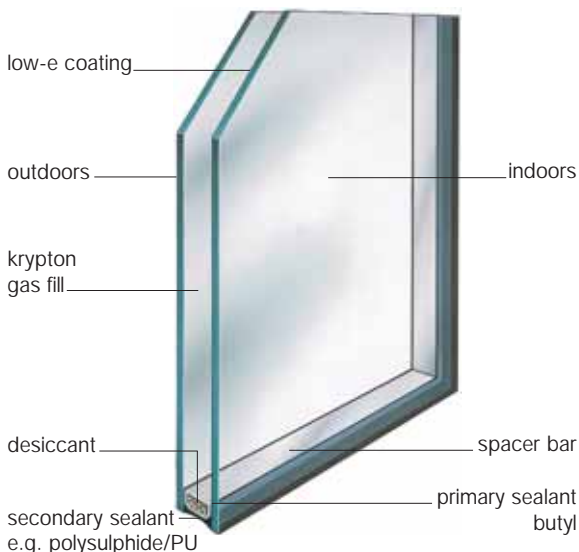

Cross-section through iplus CE

## 5 Description of INTERPANE Products



### Delivery programme for iplus CE and iplus 2CE

#### Technical data: iplus CE and iplus 2CE

product name	configuration outer/ space/inner	U <sub>g</sub> value according to EN 673	rated light and solar-radiation properties according to EN 410			thickness	mass	max. dimensions	max. area	max. ratio of side lengths
			g value	light transmittance	general colour rendering index in transmission					
	mm	W/m <sup>2</sup> K <sup>-1</sup>	%	%	–	mm	kgm <sup>2</sup>	cm	m <sup>2</sup>	–
iplus CE	4/10/4	1.0	60	80	97	18	20	141 x 240	3.40	1 : 6
iplus CE	5/10/6	1.0	59	78	96	21	27	245 / 300	6.00	1 : 10
iplus CE	6/10/6	1.0	58	78	96	22	30	250 / 400	8.00	1 : 10
iplus CE	4/12/4	1.1	60	80	97	20	20	141 x 240	3.40	1 : 6
iplus CE	5/12/6	1.1	59	78	96	23	27	245 / 300	6.00	1 : 10
iplus CE	6/12/6	1.1	58	78	96	24	30	250 / 400	8.00	1 : 10
iplus CE	4/14/4	1.1	60	80	97	22	20	141 x 240	3.40	1 : 6
iplus CE	5/14/6	1.1	59	78	96	25	27	245 / 300	6.00	1 : 10
iplus CE	6/14/6	1.1	58	78	96	26	30	250 / 400	8.00	1 : 10
iplus CE	4/16/4	1.1	60	80	97	24	20	141 x 240	3.40	1 : 6
iplus CE	5/16/6	1.1	59	78	96	27	27	245 / 300	6.00	1 : 10
iplus CE	6/16/6	1.1	58	78	96	28	30	250 / 400	8.00	1 : 10
iplus 2CE	4/10/4	1.0	52	78	96	18	20	141 x 240	3.40	1 : 6
iplus 2CE	6/10/6	1.0	50	77	95	22	30	250 / 400	8.00	1 : 10
iplus 2CE	4/12/4	1.0	52	78	96	20	20	141 x 240	3.40	1 : 6
iplus 2CE	6/12/6	1.0	50	77	95	24	30	250 / 400	8.00	1 : 10
iplus 2CE	4/14/4	1.0	52	78	96	22	20	141 x 240	3.40	1 : 6
iplus 2CE	6/14/6	1.0	50	77	95	26	30	250 / 400	8.00	1 : 10
iplus 2CE	4/16/4	1.0	52	78	96	24	20	141 x 240	3.40	1 : 6
iplus 2CE	6/16/6	1.0	50	77	95	28	30	250 / 400	8.00	1 : 10

- The customer ordering our products is responsible for ensuring that the glass thickness is dimensioned correctly according to the applicable technical regulations.
- The specified rated values refer to the testing conditions and the application scope of the referenced standard.

### 5.3.6 iplus thermally insulating triple glazing with iplus L and iplus E

Although triple glazing was (and is) primarily used until now as an ideal product for passive and lowest-energy buildings, this type of glazing is being demanded increasingly also for conventional housing construction and high-grade building renovation due to awareness of CO<sub>2</sub> emissions and the explosion in energy costs.

In particular, high-quality windows need high-performance glazing, which is why INTERPANE offers new, future-oriented products for these application areas.

Today, it can already be foreseen that future tightening of the energy-saving regulations will effectively prescribe the installation of triple glazing. Another reason to act today!

#### iplus 3E and iplus 3CE

These well-known and well-proven products from the passive-building series have  $U_g$  values down to 0.5 W/m<sup>2</sup>K according to EN 673 and thus minimise thermal losses. iplus 3E and 3CE glazing consists of combinations with iplus E basic coated glass.

#### iplus 3L and iplus 3CL

Taking account of the specific physical properties of triple glazing, INTERPANE has developed special basic coated glass for energy-optimised triple glazing units.

The emissivity of this coating (see Section 4.2) is higher than for iplus E basic coated glass. The coating design allows iplus 3L and iplus 3CL to achieve higher light transmittance and a higher total solar energy transmittance (g value).

Despite this optimisation for transmission of solar radiation,  $U_g$  values down to 0.5 W/m<sup>2</sup>K according to EN 673 are also achieved with these products.

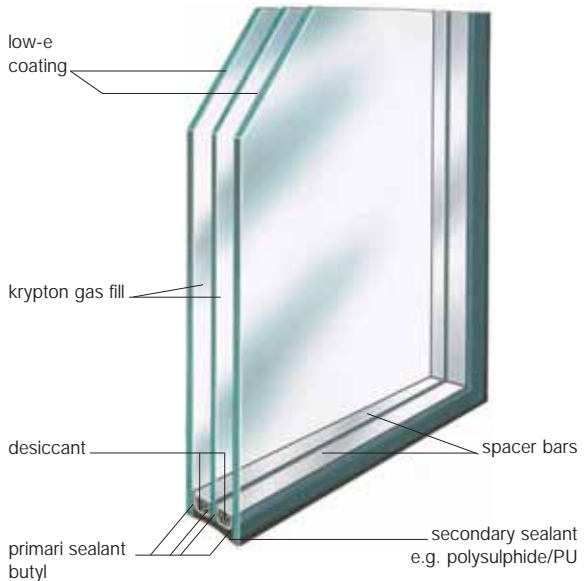

Cross-section through iplus 3CL

#### Optimal edge sealing systems

To optimise the excellent energy performance of high-quality triple glazing, the use of thermally improved edge sealing systems ("warm edge") is recommended.

#### Criteria for super-insulating glazing

The renowned "Passivhaus-Institut Dr. Feist" in Darmstadt specifies a  $U_g$  value of  $\leq 0.80$  W/m<sup>2</sup>K as a comfort criterion. In addition, the energy criterion specifies a positive energy balance for the glazing.



#### Energy criterion:

$$U_g - 1.6 \text{ W/m}^2\text{K} \times g \text{ value} \leq 0$$

All iplus thermally insulating triple glazing units from INTERPANE, both from the iplus 3E series and the iplus 3L series, meet the criteria of the Passivhaus-Institut.

#### Example:

iplus 3E  
with 2 x 14 mm space width  
 $0.64 - 1.6 \times 0.47 = -0.112$

iplus 3L  
with 2 x 16 mm space width  
 $0.62 - 1.6 \times 0.55 = -0.260$

## 5 Description of INTERPANE Products



### Delivery programme for iplus triple glazing

#### Technical data: iplus 3E and iplus 3CE

product name	configuration outer/ space/inner	U <sub>g</sub> value according to EN 673	rated light and solar-radiation properties according to EN 410			thickness	mass	max. dimensions	max. area	max. ratio of side lengths
			g value	light transmittance	general colour rendering index in transmission					
	mm	W/m <sup>2</sup> K	%	%	–	mm	kgm <sup>2</sup>	cm	m <sup>2</sup>	–
iplus 3E	4/16/4/16/4	0.6	47	71	95	44	30	141 x 240	3.40	1 : 6
iplus 3E	4/14/4/14/4	0.6	47	71	95	40	30	141 x 240	3.40	1 : 6
iplus 3E	4/12/4/12/4	0.7	47	71	95	36	30	141 x 240	3.40	1 : 6
iplus 3CE	4/12/4/12/4	0.5	47	71	95	36	30	141 x 240	3.40	1 : 6
iplus 3CE	4/10/4/10/4	0.6	47	71	95	32	30	141 x 240	3.40	1 : 6

– max. unit thickness: 46 mm

– max. unit mass: 250 kg

- The customer ordering our products is responsible for ensuring that the glass thickness is dimensioned correctly according to the applicable technical regulations.
- The specified rated values refer to the testing conditions and the application scope of the referenced standard.
- For optical reasons, the use of black spacers is recommended.

#### Technical data: iplus 3L and iplus 3CL

product name	configuration outer/ space/inner	U <sub>g</sub> value according to EN 673	rated light and solar-radiation properties according to EN 410			thickness	mass	max. dimensions	max. area	max. ratio of side lengths
			g value	light transmittance	general colour rendering index in transmission					
	mm	W/m <sup>2</sup> K	%	%	–	mm	kgm <sup>2</sup>	cm	m <sup>2</sup>	–
iplus 3L	4/16/4/16/4	0.6	55	72	96	44	30	141 x 240	3.40	1 : 6
iplus 3L	4/14/4/14/4	0.7	55	72	96	40	30	141 x 240	3.40	1 : 6
iplus 3L	4/12/4/12/4	0.8	55	72	96	36	30	141 x 240	3.40	1 : 6
iplus 3CL	4/12/4/12/4	0.5	55	72	96	36	30	141 x 240	3.40	1 : 6
iplus 3CL	4/10/4/10/4	0.6	55	72	96	32	30	141 x 240	3.40	1 : 6

– max. unit thickness: 46 mm

– max. unit mass: 250 kg

- The customer ordering our products is responsible for ensuring that the glass thickness is dimensioned correctly according to the applicable technical regulations.
- The specified rated values refer to the testing conditions and the application scope of the referenced standard.
- For optical reasons, the use of black spacers is recommended.

### 5.3.7 iplus city E - Multifunctional glazing

Triple protection for discerning customers

Particularly for private homes and building objects in prime locations, building owners frequently demand windows and glazing with special features which meet the occupants' expectations of greater comfort, higher living quality and more security.

Not only is excellent thermal insulation specified, but usually also protection against burglary and good sound insulation. Standard glazing does not suffice here.

iplus city E is an attractive, multifunctional addition to the iplus product family, which meets the special demands of high-quality homes in urban locations.

iplus city E combines three essential functions:

- thermal insulation  
excellent  $U_g$  value of  $1.1 \text{ W/m}^2\text{K}$  according to EN 673
- anti-burglar protection  
resistance to manual attack (P4A) according to EN 356
- sound insulation  
sound insulation value of up to 38 dB, thus meeting sound insulation category 3 according to VDI 2719

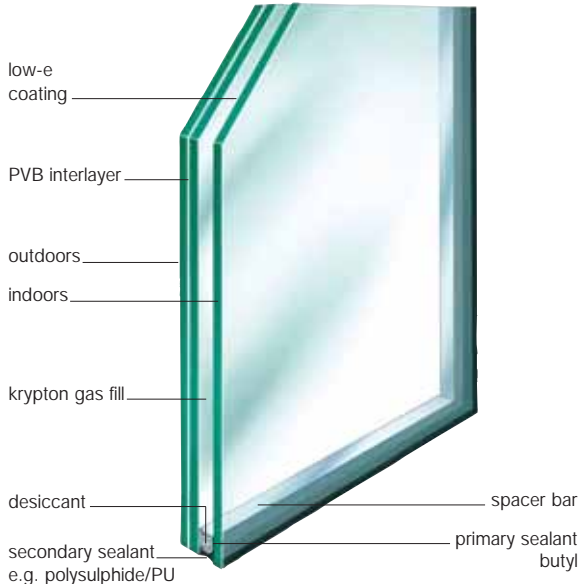

Cross-section through iplus city E

In addition, the thickness of the insulating glass unit, only 26 mm, allows it to be installed into almost all window constructions without difficulty.

With this triple combination of protective properties, iplus city E is an extremely effective addition to the iplus E product family. It offers more living quality for an economical price.

## Delivery programme for iplus city E

### Technical data: iplus city E

Configuration outer/ space/inner	U <sub>g</sub> value according to EN 673	R <sub>v</sub> measured value of sound reduction index	correction values				anti-burglar protection	rated light and solar-radiation properties according to EN 410		
			C	C <sub>tr</sub>	C <sub>100-5000</sub>	C <sub>tr 100-5000</sub>		EN 356	g value	light transmittance
mm	W/m <sup>2</sup> K	dB	dB					%	%	-
10(P4A)/16/4	1.1	38	-3	-8	-2	-8	P4A	53	77	95
10(P4A)/12/4	1.1	37	-3	-7	-2	-7	P4A	53	77	95

thickness	mass	max. dimensions	max. area	max. ratio of side lengths
mm	kg/m <sup>2</sup>	cm	m <sup>2</sup>	-
30	34	141 x 240	3.40	1 : 6
26	34	141 x 240	3.40	1 : 6

- Please note that for thicker panes, the intrinsic green/yellow colouring of the insulating glass units becomes more evident.
- The customer ordering our products is responsible for ensuring that the glass thickness is dimensioned correctly according to the applicable technical regulations.
- The specified rated values refer to the testing conditions and the application scope of the referenced standard.

## 5 Description of INTERPANE Products



### 5.3.8 iplus sun - climate glazing

Now a glazing type is available for everyone, particularly private home owners, that suits our changeable climate - iplus sun.

Conservatories or glazed extensions quickly overheat in summer when the sun shines strongly, but become unpleasantly cold in winter.

iplus sun offers ideal protection against overheating in summer, as the g value (total solar energy transmittance) has been reduced to 43 %, while the light transmittance is still a high 71 %. The  $U_g$  value of 1.1 W/m<sup>2</sup>K according to EN 673 is very respectable and provides effective protection against thermal losses in winter.

iplus sun makes sure that the indoor climate is right.

### Delivery programme for iplus sun climate glazing

#### Technical data: iplus sun

product name	configuration outer/ space/inner	$U_g$ value according to EN 673	rated light and solar-radiation properties according to EN 410			thickness	mass	max. dimensions	max. area	max. ratio of side lengths
			g value	light transmittance	shading coefficient					
	mm	W/m <sup>2</sup> K	%	%	–	mm	kgm <sup>2</sup>	cm	m <sup>2</sup>	–
iplus sun	4/16/4	1.1	43	71	0.54	24	20	141 x 240	3.40	1 : 6
iplus sun	6/16/5	1.1	42	70	0.53	27	27	245 / 300	6.00	1 : 10
iplus sun	6/16/6	1.1	42	69	0.53	28	30	250 / 400	8.00	1 : 10
iplus sun	4/14/4	1.2	43	71	0.54	22	20	141 x 240	3.40	1 : 6
iplus sun	6/14/5	1.1	42	70	0.53	25	27	245 / 300	6.00	1 : 10
iplus sun	6/14/6	1.1	42	69	0.53	26	30	250 / 400	8.00	1 : 10
iplus sun	4/12/4	1.3	43	71	0.54	20	20	141 x 240	3.40	1 : 6
iplus sun	6/12/5	1.3	42	70	0.53	23	27	245 / 300	6.00	1 : 10
iplus sun	6/12/6	1.3	42	69	0.53	24	30	250 / 400	8.00	1 : 10

- The customer ordering our products is responsible for ensuring that the glass thickness is dimensioned correctly according to the applicable technical regulations.
- The specified rated values refer to the testing conditions and the application scope of the referenced standard.



iplus E/ipaphon glazing from INTERPANE combines sound-insulating and high-quality thermally insulating properties on a standard basis. For architecture in noisy locations.

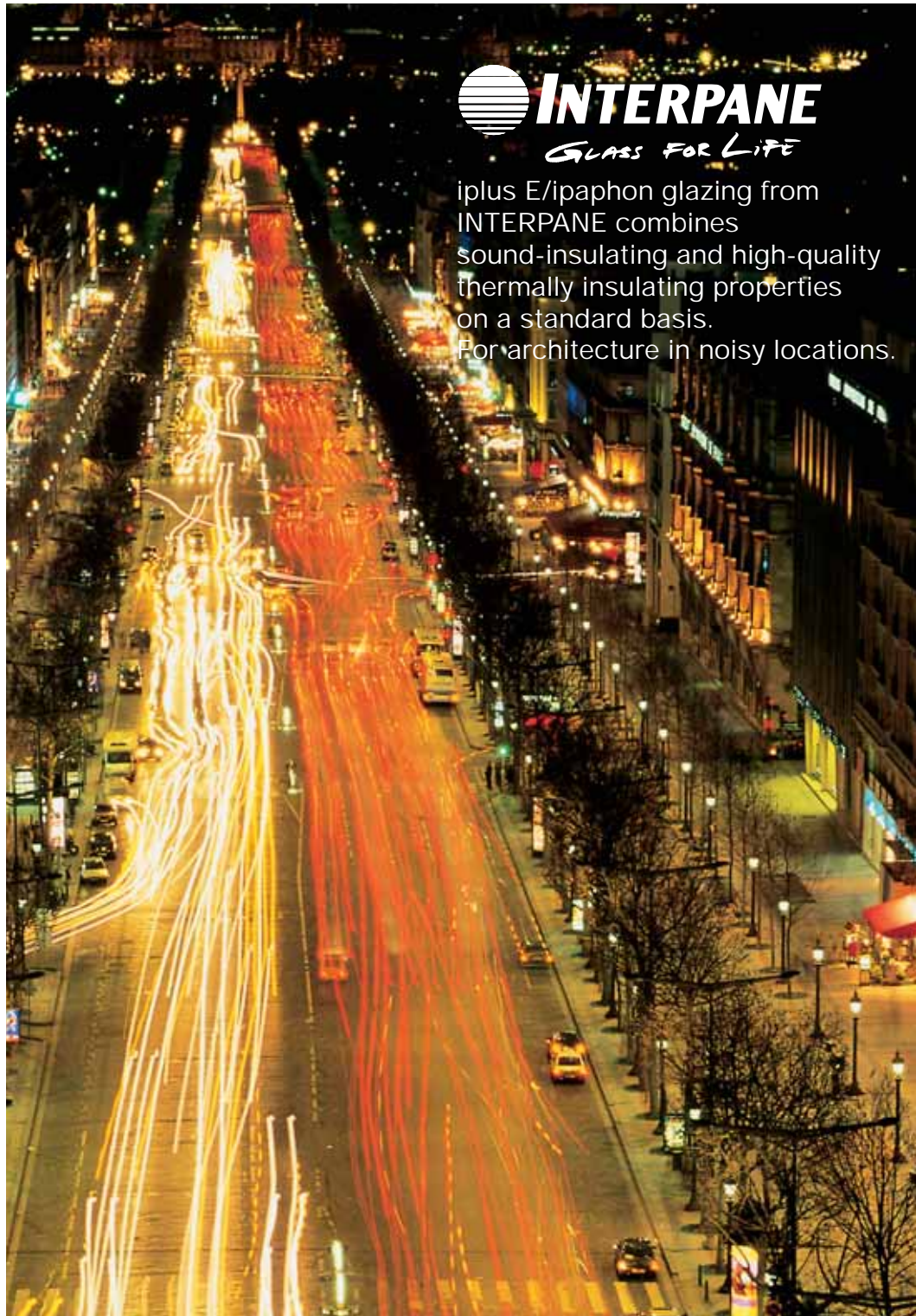

## 5 Description of INTERPANE Products



### 5.4 iplus E/ipaphon sound-insulating glazing

Complete environmental protection demands not only protection against noise but also protection of our natural surroundings.

The German energy-saving ordinance demands fundamental and significant improvement of the thermal insulation in new and old buildings. Thus, modern sound-insulating double glazing must not only cover a wide range of sound insulation (up to  $R_w = 52$  dB) but also strongly reduce thermal transmission losses.

The ipaphon sound-insulating glazing range is thus combined with the high-quality iplus E coating on a standard basis.

All ipaphon types can also be combined with almost all ipasol coatings instead of iplus E.

The sound insulation remains unchanged while the energy-relevant technical values are close to those of the ipasol type used.

Your INTERPANE supplier will be happy to determine the technical values of the ipasol/ipaphon combination of your choice.

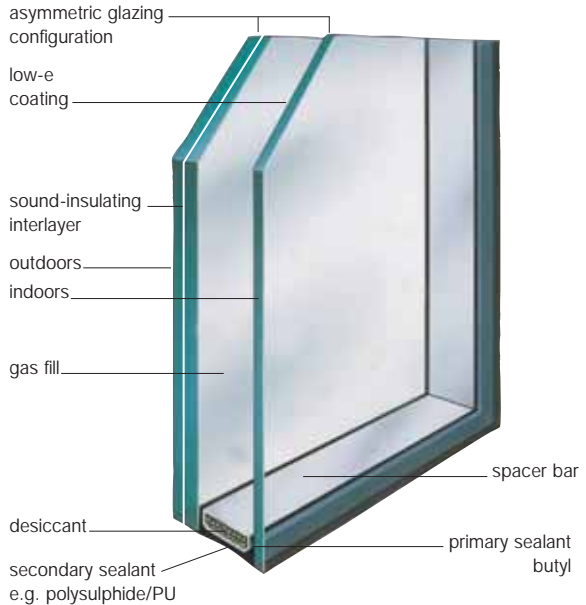

Cross-section through iplus E/ipaphon S

### 5.4.1 Building science fundamentals

The complete window unit is important in achieving protection against noise, i.e. window frame, sealant, installation in the facade and sound-insulating glazing unit.

Individual details on determining the sound insulation needed for a window are described comprehensively in Section 3.5.

The quantity used to characterise protection against noise is the weighted sound reduction index  $R_{w}$  4109, also known as the  $R_{w}$  value. It is measured in dB.

It is recommended that information regarding sound insulation be validated by measurements on the complete window unit according to EN 20140 or EN ISO 717.

The physical principles applying to transmission of sound differ fundamentally from those relating to heat transfer.

A rule of thumb is: The sound insulation depends on the mass per area of the installed building component.

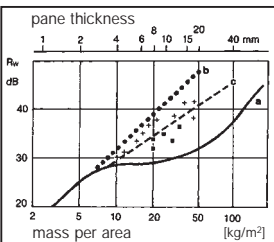

weighted sound reduction index  $R_{w}$  of single and laminated glass panes

- single pane
- + laminated glass
- a) stiff plate
- b) flexible plate
- c) single pane (according to VDI 2719)

This diagram applies only to single glazing.

In addition, the double-glazed configuration of sound-insulating glazing generally improves the weighted sound reduction index. However, due to coupling between the panes via the intervening gas space, resonances occur which reduce the sound insulation in the lower frequency range.

These effects mean that a normal double (4/12/4) or triple (4/8/4/8/4) glazing unit will not improve the sound insulation significantly compared to a single pane with the same mass per area as that of the constituent panes of the multiple glazing.

The sound insulation provided by an insulating glass unit is determined by the following parameters:

#### a) Pane mass

The greater the mass per area of a pane, the higher is the sound reduction index in general.

#### b) Pane stiffness

The more flexible a pane is, the higher is the sound reduction index in general. Laminated glass panes with a sound-insulating interlayer exploit this proven effect: The elastic connection of two thin single panes combines a high mass per area with a low bending stiffness.

In this way, the sound insulation is improved both in the lower and the upper frequency range.

In addition, the laminated glass has the effect of reducing sound conduction through the edge spacer of the insulating glass unit.

#### c) Glazing configuration

The thickness of the external and internal panes must be different. In general, the more asymmetric the glazing unit

configuration is, the greater is the sound reduction index, as the resonant frequencies for the individual panes are different.

#### d) Gas space width

In general, the wider the gas space is, the higher is the sound reduction index, as the cavity resonance is shifted to lower frequencies.

A change in the gas space width is usually accompanied by a change in the U value (see Section 5.3.3).

#### e) Gas fill

To protect the environment, INTERPANE no longer uses  $SF_6$  to improve the sound insulation. Argon and krypton, the gases used, change both the sound insulation and the thermal insulation.

In the discussion above of the determining factors, "in general" has been deliberately included. Particularly in reference to sound insulation, a general discussion can not adequately cover all aspects of the specific individual case.

Optimal individual results do not always combine to give a better result. This is due to the interaction between the individual parameters.

The sound reduction index of an insulating glass unit can be planned on the basis of the physical and technical knowledge indicated here, but its exact value can only be determined by measurement.

A calculation-based determination using the mass per area is neither correct nor permissible.

## 5 Description of INTERPANE Products



Reduction of sound insulation due to obliquely incident sound waves

Depending on the installation position, directional sound waves can be obliquely incident on the glazing, e.g. in tall buildings on streets with heavy traffic.

In these cases, the conditions of the test stand are very different to those encountered in reality. The actual sound insulation is lower than that determined in the test stand.

Account can be taken of this fact by specifying higher values for the sound insulation than those determined according to DIN 4109 (see Section 3.5).

Reduction of sound insulation in the lower frequency range

In all glazing configurations with two or more panes, a clear reduction in the sound insulation can be found in the lower frequency range at 125 Hz to 250 Hz. This is clearly evident in the measurement curves of the relevant test certificates for sound insulation.

Thus, even if the  $R_w$  value is 44 dB, the sound reduction index falls to 20 dB in this lower frequency range.

However, this property should not be overemphasised, as human hearing is relatively insensitive specifically in the lower frequency range.

Better protection against deep, dull sounds from heavy traffic can always be achieved by installing heavy, flexible, asymmetric, sound-insulating double glazing. Its sound insulation is better for the lower frequency range than that of stiff monolithic glazing.

Spectral adaptation values ( $C$ ,  $C_{tr}$ )

The European standard, EN ISO 717, to determine the acoustic properties of buildings and building components offers the option of adapting the measured sound reduction index with so-called "spectral adaptation values"  $C$  and  $C_{tr}$  (see Section 4.9) to the existing outdoor noise spectrum.

Effect of glazing bars on sound insulation

Genuine glazing bars (muntins) have the disadvantage that they act as thermal and acoustic bridges. If there is a large number of glazing bars, significant sound transmission can occur due to imperfect joints between the bars. This disadvantage can be reduced by careful workmanship. In addition, glazing bars create thermal bridges.

Modern glazing bar systems which are integrated into the space between the panes, e.g. "Swiss cross" or "Viennese cross", largely avoid these negative effects (see Section 5.12.2).

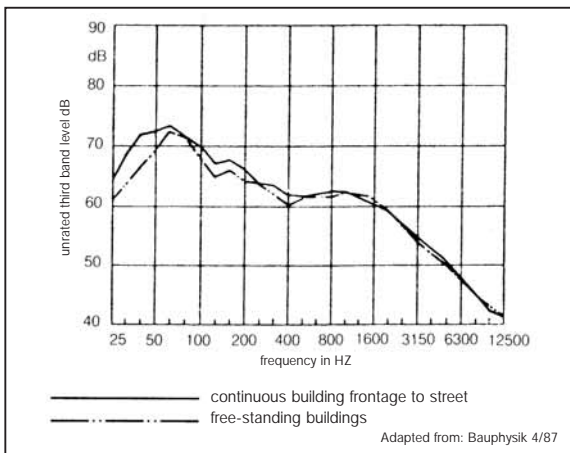

Average values of noise spectra due to road traffic in situations with continuous and interrupted street frontages.

### 5.4.2 Planning criteria for the application of iplus E/ipaphon sound-insulating glazing with two or more panes

Combining the functions of sound insulation with thermal insulation or solar control demands clear specification of the individual functional properties already during the planning phase.

Due to the characteristic features of sound-insulating double glazing, such as

- wider gas-filled spaces and
- asymmetric glazing configuration,

a list of further criteria must be tested:

- As a fundamental principle, the thicker glass pane of

the sound-insulating double-glazed unit should be positioned outdoors to minimise distortions due to the "double-glazing effect" and to withstand wind loads.

- In small insulating glass units, i.e. where the edge length is < 50 cm, for gas-filled space widths exceeding > 16 mm and/or where the ratio of side lengths is unfavourable, the edge seal is subjected to extremely high loads.

Thus, already before the main planning phase, it is necessary to find an integrated solution concerning the configuration of

the insulating glass units, the dimensioning of the edge seal and the glass. If necessary, the thinner pane must be made of thermally toughened glass.

- The usage of glass with high solar absorptance values, e.g. absorbing solar-control glass, generally requires the gas-filled space width to be limited to a maximum of 16 mm. In addition, the need for thermally toughened glass must already be determined during the planning phase.

## 5 Description of INTERPANE Products



### 5.4.3 Product range of sound-insulating double glazing with iplus E/ipaphon

iplus E/ipaphon sound-insulating double glazing is distinguished by the combination of panes with different thicknesses, usually wider spaces between the panes, the gas fill and in some cases, the use of laminated glass. This laminated glass is produced with special sound-insulating interlayers, which can

also have additional safety-relevant properties (ipaphon SF).

With gas fills,  $U_g$  values down to 1.1 W/m<sup>2</sup>K according to EN 673 can be achieved.

The product name for iplus E/ipaphon sound-insulating double glazing consists of the

following elements:

- rated sound reduction index  $R_w$  in dB
- thickness of insulating glass unit in mm
- ID for pane configuration with interlayer
- $U_g$  value in W/m<sup>2</sup>K according to EN 673

INTERPANE sound-insulating products feature good thermal insulation (iplus E coating). The product spectrum covers the following groups:

Product group	Function / Sound-insulating glazing configurations	Example
● iplus E / ipaphon	sound insulation with float glass or with P2A or laminated glass (German: Verbundsicherheitsglas)	36/26-1.1 37/29 V-1.1
● iplus E / ipaphon S	increased sound insulation interlayer (German: Schallschutz)	44/35 VG-1.1
● iplus E / ipaphon SF	increased sound insulation with sound-insulating/safety-glass interlayer (German: Sicherheitsfolie)	46/37 SF-1.1
● iplus CE / ipaphon	sound insulation with float glass and krypton gas fill	37/22-1.1
● iplus CE / ipaphon SF	increased sound insulation with sound-insulating/safety-glass interlayer and krypton gas fill	49/38 SF-1.1

Example for increased sound insulation with a sound-insulating interlayer

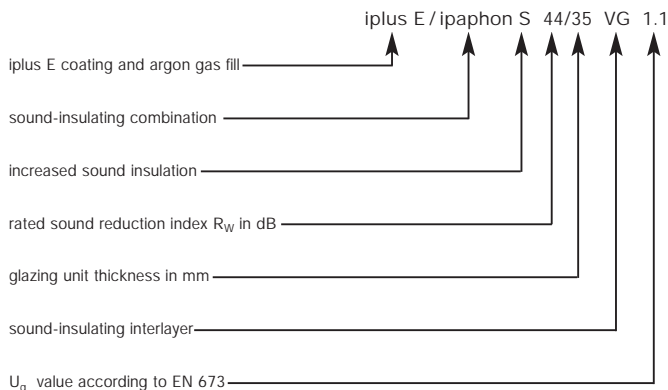

## 5 Description of INTERPANE Products

### Delivery programme for iplus E/ipaphon

### sound-insulating double glazing with increased thermal insulation

#### Technical data: iplus E/ipaphon combined thermal insula

product name	type	configuration outer/ space/inner	R <sub>w</sub> measured value EN 20140	correction values			
				C	C <sub>tr</sub>	C <sub>100-5000</sub>	C <sub>tr 100-5</sub>
		mm	dB	dB			
iplus E/ipaphon	36/26-1.1	6/16/4	36	-2	-5	-1	-5
iplus E/ipaphon	37/28-1.1	8/16/4	37	-2	-5	-1	-5
iplus E/ipaphon	37/29 V-1.1	9(P2A)/16/4***	37	-2	-6	-1	-6
iplus E/ipaphon	38/26 V-1.3*	6/12/8VSG	38	-1	-5	-0	-5
iplus E/ipaphon	39/34-1.1	10/20/4	39	-2	-6	-1	-6
iplus E/ipaphon	43/36 V-1.1*	8/16/12VSG	43	-2	-6	-1	-6
iplus CE/ipaphon	37/22-1.1	6/12/4	37	-3	-7	-2	-7
iplus CE/ipaphon	37/26-1.1	6/16/4	37	-3	-8	-2	-8
iplus CE/ipaphon	39/26-1.1	10/12/4	39	-3	-7	-2	-8
iplus CE/ipaphon	40/30-1.1	10/16/4	40	-4	-9	-3	-9
iplus CE/ipaphon SF	43/31 SF-1.1	SF9/16/6****	43	-3	-8	-2	-8
iplus CE/ipaphon SF	49/38 SF-1.1	SF13/16/SF9****	49	-3	-9	-2	-9
iplus E/ipaphon S	41/31 VG-1.1	VG9/16/6	41	-2	-7	-1	-7
iplus E/ipaphon S	44/35 VG-1.1	VG9/16/10	44	-2	-6	-1	-6
iplus E/ipaphon S	45/39 VG-1.1	VG13/16/10	45	-2	-5	-1	-5
iplus E/ipaphon S	48/38 VG-1.1	VG13/16/VG9	48	-2	-7	-1	-7
iplus E/ipaphon SF	41/31 SF-1.1	SF9/16/6****	41	-3	-8	-2	-8
iplus E/ipaphon SF	45/35 SF-1.1	SF9/16/10****	45	-3	-8	-2	-8
iplus E/ipaphon SF	46/37 SF-1.1	SF11/16/10****	46	-2	-6	-1	-6
iplus E/ipaphon SF	48/38 SF-1.1	SF13/16/SF9****	48	-2	-8	-1	-8
iplus E/ipaphon SF	50/42 SF-1.3	SF13/16/SF13****	50	-2	-7	-1	-7
iplus E/ipaphon SF	52/46 SF-1.3	SF17/16/SF13****	52	-1	-5	0	-5

\* Coating at position 2.

\*\* If the ratio of side lengths exceeds 2:1, we recommend the use of ipasafe thermally toughened glass.

\*\*\* P2A according to EN 356

\*\*\*\* iplus E/ipaphon SF with a 0.76 mm interlayer has safety properties like laminated safety glass according to EN 1064.

- Please note that for thicker panes, the intrinsic green/yellow colouring of the insulating glass units becomes more pronounced.
- The customer ordering our products is responsible for ensuring that the glass thickness is dimensionally accurate.
- The specified rated values refer to the testing conditions and the application scope of the referenced standards.
- Maximum mass: 500 kg per insulating glass unit.

## and sound insulation

g ue rding I 673	rated light and solar-radiation properties according to EN 410			thickness	mass	max. dimensions	max. area	max. ratio of side lengths
	g value	light trans- mittance	general colour rendering index in transmission					
m²K	%	%	-	mm	kg/m²	cm	m²	-
.1	58	79	96	26	25	141 x 240	3.40	1 : 6
.1	56	78	95	28	30	141 x 240	3.40	1 : 6
.1	54	78	96	29	33	141 x 240	3.40	1 : 6
.3	53	76	95	26	35	225 / 400	8.00	1 : 10
.1	55	77	95	34	35	141 x 240	3.40	1 : 6**
.1	52	75	93	36	51	250 x 400	10.00	1 : 10
.1	58	79	96	22	25	141 x 240	3.40	1 : 6
.1	58	79	96	26	25	141 x 240	3.40	1 : 6
.1	55	77	95	26	35	141 x 240	3.40	1 : 6
.1	55	77	95	30	35	141 x 240	3.40	1 : 6
.1	53	76	95	31	36	250 / 400	8.00	1 : 10
.1	50	74	92	38	52	260 / 410	9.60	1 : 10
.1	53	76	95	31	36	250 / 400	8.00	1 : 10
.1	53	75	94	35	46	250 x 400	10.00	1 : 10
.1	50	74	93	39	56	250 / 400	8.90	1 : 10
.1	50	74	92	38	52	260 / 410	9.60	1 : 10
.1	53	76	95	31	36	250 / 400	8.00	1 : 10
.1	53	75	94	35	46	250 x 400	10.00	1 : 10
.1	52	75	94	37	51	250 x 400	10.00	1 : 10
.1	50	74	92	38	52	260 / 410	9.60	1 : 10
.3	50	73	91	42	62	260 / 410	9.60	1 : 10
.3	49	72	91	46	72	260 / 410	9.60	1 : 10

ie thinner pane.

) the "Technical regulations for the use of linearly edge-supported glazing".

more evident.

actly according to the applicable technical regulations.

d.

# 5 Description of INTERPANE Products



## Sound insulation curves

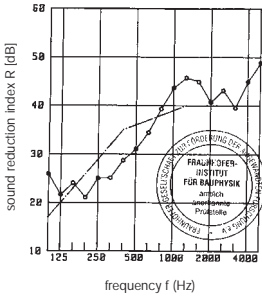

Type: 36/26-1.1

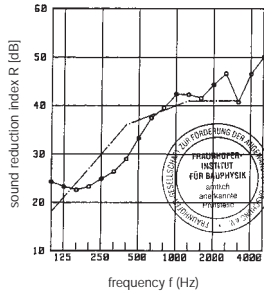

Type: 37/28-1.1

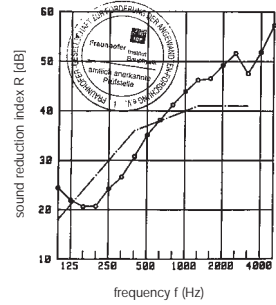

Type: 37/29 V-1.1

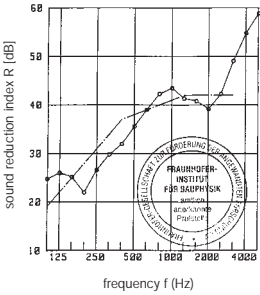

Type: 38/26 V-1.3

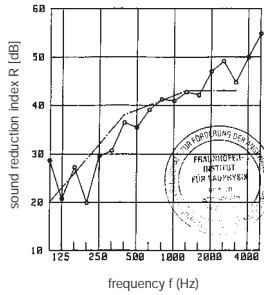

Type: 39/34-1.1

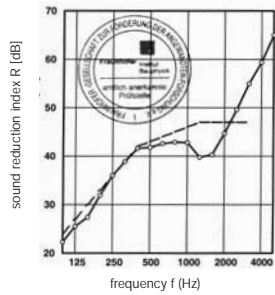

Type: 43/36V-1.1

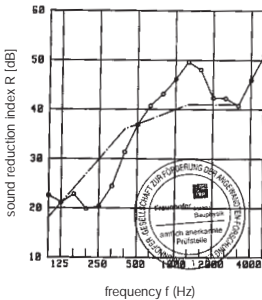

Type: 37/22-1.1

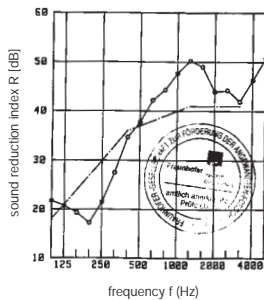

Type: 37/26-1.1

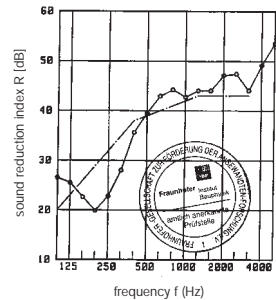

Type: 39/26-1.1

# 5 Description of INTERPANE Products



## Sound insulation curves

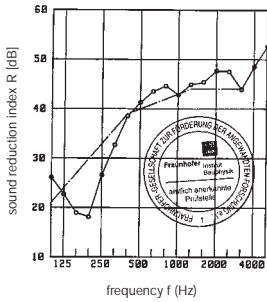

Type: 40/30-1.1

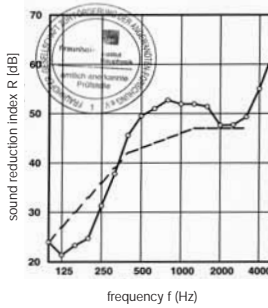

Type: 43/31 SF-1.1

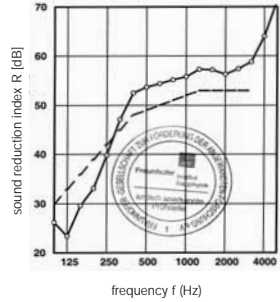

Type: 49/38 SF-1.1

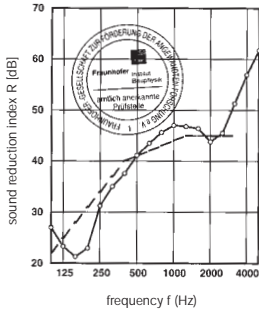

Type: 41/31 VG-1.1

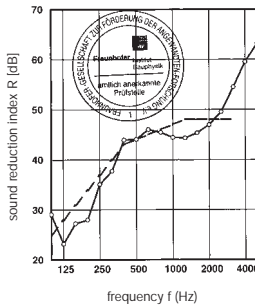

Type: 44/35 VG-1.1

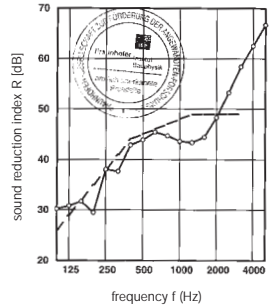

Type: 45/39 VG-1.1

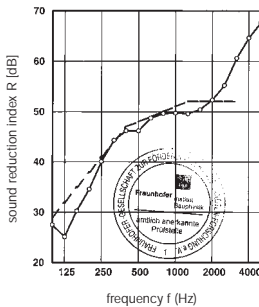

Type: 48/38 VG-1.1

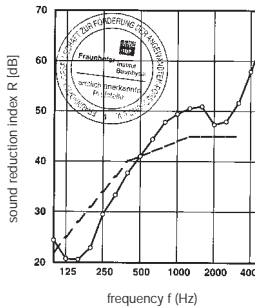

Type: 41/31 SF-1.1

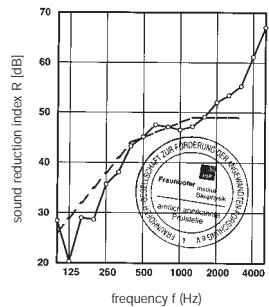

Type: 45/35 SF-1.1

## 5 Description of INTERPANE Products



### Sound insulation curves

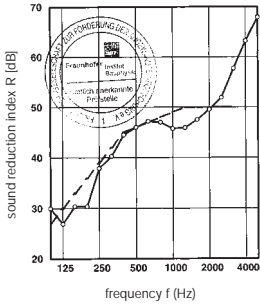

Type: 46/37 SF-1.1

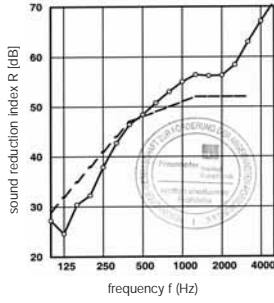

Type: 48/38 SF-1.1

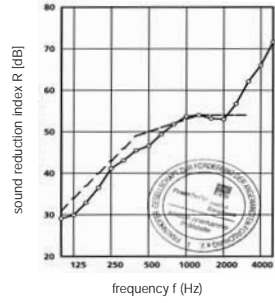

Type: 50/42 SF-1.3

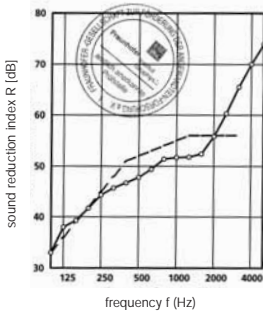

Type: 52/46 SF-1.3

## 5 Description of INTERPANE Products

### Delivery programme for iplus E/ipaphon

### sound-insulating double glazing with increased thermal insulation

#### Technical data: iplus E/ipaphon combined thermal insulation and sound insulation

product name	type	configuration outer/ space/inner	R <sub>w</sub> measured value EN 20 140	correction values				U <sub>g</sub> value according to EN 673	rated light and solar-radiation properties according to EN 410			thickness	mass	max. dimensions	max. area	max. ratio of side lengths
				C	C <sub>tr</sub>	C <sub>100-5000</sub>	C <sub>tr 100-5000</sub>		g value	light trans- mittance	general colour rendering index in transmission					
				dB					W/m²K	%	%					
iplus E/ipaphon	36/26-1.1	6/16/4	36	-2	-5	-1	-5	1.1	58	79	96	26	25	141 x 240	3.40	1 : 6
iplus E/ipaphon	37/28-1.1	8/16/4	37	-2	-5	-1	-5	1.1	56	78	95	28	30	141 x 240	3.40	1 : 6
iplus E/ipaphon	37/29 V-1.1	9(P2A)/16/4***	37	-2	-6	-1	-6	1.1	54	78	96	29	33	141 x 240	3.40	1 : 6
iplus E/ipaphon	38/26 V-1.3*	6/12/8VSG	38	-1	-5	-0	-5	1.3	53	76	95	26	35	225 / 400	8.00	1 : 10
iplus E/ipaphon	39/34-1.1	10/20/4	39	-2	-6	-1	-6	1.1	55	77	95	34	35	141 x 240	3.40	1 : 6**
iplus E/ipaphon	43/36 V-1.1*	8/16/12VSG	43	-2	-6	-1	-6	1.1	52	75	93	36	51	250 x 400	10.00	1 : 10
iplus CE/ipaphon	37/22-1.1	6/12/4	37	-3	-7	-2	-7	1.1	58	79	96	22	25	141 x 240	3.40	1 : 6
iplus CE/ipaphon	37/26-1.1	6/16/4	37	-3	-8	-2	-8	1.1	58	79	96	26	25	141 x 240	3.40	1 : 6
iplus CE/ipaphon	39/26-1.1	10/12/4	39	-3	-7	-2	-8	1.1	55	77	95	26	35	141 x 240	3.40	1 : 6
iplus CE/ipaphon	40/30-1.1	10/16/4	40	-4	-9	-3	-9	1.1	55	77	95	30	35	141 x 240	3.40	1 : 6
iplus CE/ipaphon SF	43/31 SF-1.1	SF9/16/6****	43	-3	-8	-2	-8	1.1	53	76	95	31	36	250 / 400	8.00	1 : 10
iplus CE/ipaphon SF	49/38 SF-1.1	SF13/16/SF9****	49	-3	-9	-2	-9	1.1	50	74	92	38	52	260 / 410	9.60	1 : 10
iplus E/ipaphon S	41/31 VG-1.1	VG9/16/6	41	-2	-7	-1	-7	1.1	53	76	95	31	36	250 / 400	8.00	1 : 10
iplus E/ipaphon S	44/35 VG-1.1	VG9/16/10	44	-2	-6	-1	-6	1.1	53	75	94	35	46	250 x 400	10.00	1 : 10
iplus E/ipaphon S	45/39 VG-1.1	VG13/16/10	45	-2	-5	-1	-5	1.1	50	74	93	39	56	250 / 400	8.90	1 : 10
iplus E/ipaphon S	48/38 VG-1.1	VG13/16/VG9	48	-2	-7	-1	-7	1.1	50	74	92	38	52	260 / 410	9.60	1 : 10
iplus E/ipaphon SF	41/31 SF-1.1	SF9/16/6****	41	-3	-8	-2	-8	1.1	53	76	95	31	36	250 / 400	8.00	1 : 10
iplus E/ipaphon SF	45/35 SF-1.1	SF9/16/10****	45	-3	-8	-2	-8	1.1	53	75	94	35	46	250 x 400	10.00	1 : 10
iplus E/ipaphon SF	46/37 SF-1.1	SF11/16/10****	46	-2	-6	-1	-6	1.1	52	75	94	37	51	250 x 400	10.00	1 : 10
iplus E/ipaphon SF	48/38 SF-1.1	SF13/16/SF9****	48	-2	-8	-1	-8	1.1	50	74	92	38	52	260 / 410	9.60	1 : 10
iplus E/ipaphon SF	50/42 SF-1.3	SF13/16/SF13****	50	-2	-7	-1	-7	1.3	50	73	91	42	62	260 / 410	9.60	1 : 10
iplus E/ipaphon SF	52/46 SF-1.3	SF17/16/SF13****	52	-1	-5	0	-5	1.3	49	72	91	46	72	260 / 410	9.60	1 : 10

\* Coating at position 2.

\*\* If the ratio of side lengths exceeds 2:1, we recommend the use of ipasafe thermally toughened glass for the thinner pane.

\*\*\* P2A according to EN 356

\*\*\*\* iplus E/ipaphon SF with a 0.76 mm interlayer has safety properties like laminated safety glass according to the "Technical regulations for the use of linearly edge-supported glazing".

- Please note that for thicker panes, the intrinsic green/yellow colouring of the insulating glass units becomes more evident.
- The customer ordering our products is responsible for ensuring that the glass thickness is dimensioned correctly according to the applicable technical regulations.
- The specified rated values refer to the testing conditions and the application scope of the referenced standard.
- Maximum mass: 500 kg per insulating glass unit

ipanol solar-control insulating glazing from INTERPANE for modern glass architecture: Highly effective solar control combined with high light transmission. A comprehensive range of high-performance ipanol products opens up a wide and attractive field for the planner.



**INTERPANE**  
*GLASS FOR LIFE*

### 5.5 ipasol solar-control glazing

Characteristic features of solar-control glazing for prestigious buildings include low total solar energy transmittance ( $g$  value), good thermal insulation ( $U_g$  value) and the highest possible light transmittance ( $\tau_v$ ). Above all, however, aesthetic demands regarding colour and reflection must be met.

Whereas the desired low  $g$  values were always accompanied by significantly reduced light transmittance values in conventional solar-control glazing, modern coating technology has made highly selective solar-control coatings with extremely low  $U_g$  values feasible.

These high-tech products are primarily used for high-profile buildings with large glazed areas.

Large areas of glass can lead to a high energy consumption for air-conditioning in summer. The cooling costs are sometimes much higher than the heating costs in winter.

The low  $g$  value provides relief here and thus reduces costs. In addition, the low  $U_g$  value causes drastic cost savings in winter. These two characteristics also have a positive effect on the investment costs for building technology.

The complete set of technical data predestines ipasol not only for application in our temperate climatic zone but also in tropical and sub-tropical regions with their extreme climatic conditions.

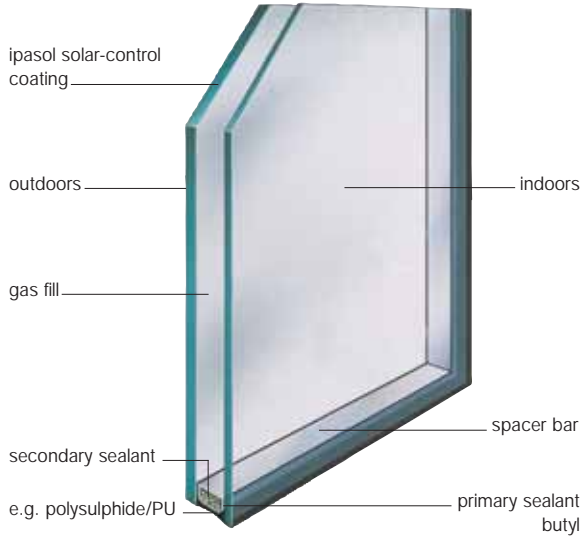

Cross-section through ipasol

### 5.5.1 Product range of ipasol solar-control insulating glazing

The ipasol product range consists of solar-control glazing types which transmit natural daylight unusually well but nevertheless feature extraordinarily low solar gains.

These highly selective solar-control coatings approach the limits of what is physically feasible with their performance.

If the outdoor reflectance is low, glass façades with high transparency in both directions can become reality. Energy-efficient buildings that are visibly "filled with life" can be achieved this way.

Highly reflective ipasol products set architectural accents, so that every design concept can be implemented.

Design freedom, particularly for completely glazed façades, is further extended by a range of matching spandrel elements.

ipasol is also produced with modern, high-performance coating technology (see Sections 5.3.1 and 5.3.2).

In most cases, the coating is located on the inner surface of the outdoor pane, facing the gas-filled space (position 2).

Exceptions may be made for optical reasons, when the coating will be located at a different position.

For ipasol, the solar-control coating is always deposited onto glass with a thickness of 6 mm, unless

mechanical requirements demand thicker glass.

By using thinner glass for the second pane, optical distortion in the façade due to the "double-glazing effect" is reduced.

If the space between the panes in solar-control glazing is thicker than 16 mm to improve sound insulation, the configuration of the insulating glass units should already be checked during the planning phase with regard to the "double-glazing effect" (see Section 4.10).

## 5 Description of INTERPANE Products



The colour of the outdoor appearance and the intensity of reflected light can be derived from the spectral reflectance values in the visible range from 380 nm to 780 nm.

### ipasol platin 25/14

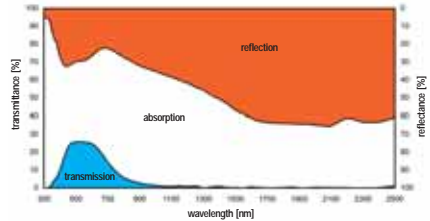
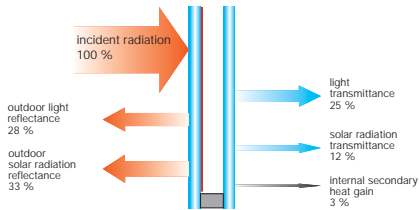

### ipasol shine 40/21

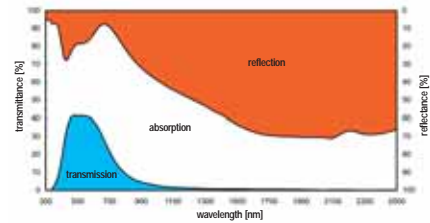
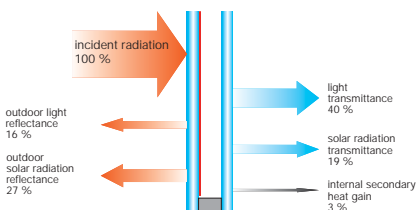

### ipasol neutral 48/25

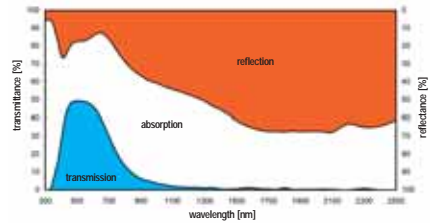
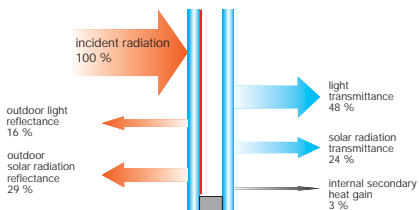

### ipasol neutral 50/25

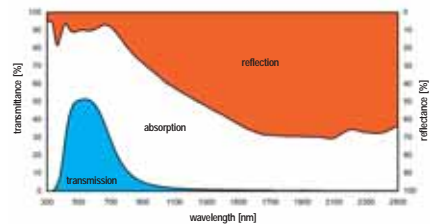
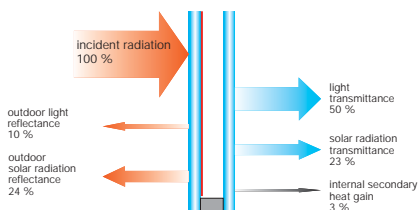

The specified rated values refer to the testing conditions and the application scope of the relevant standard.

## 5 Description of INTERPANE Products



The colour of the outdoor appearance and the intensity of reflected light can be derived from the spectral reflectance values in the visible range from 380 nm to 780 nm.

### ipasol platin 47/28

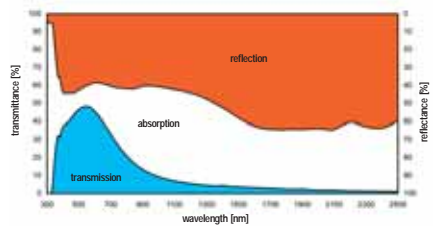
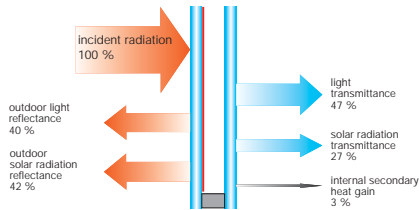

### ipasol neutral 60/31

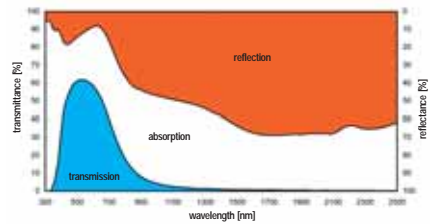
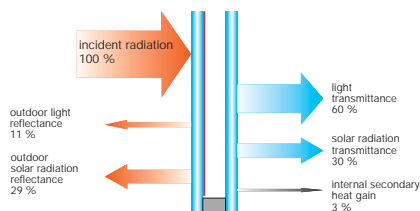

### ipasol neutral 68/34

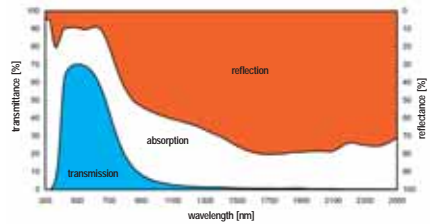
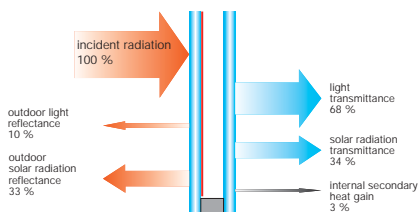

### ipasol neutral 70/36

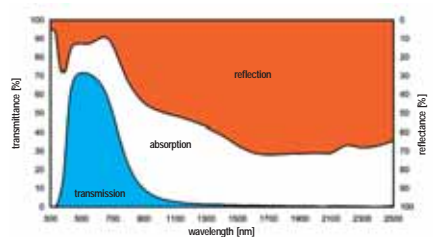
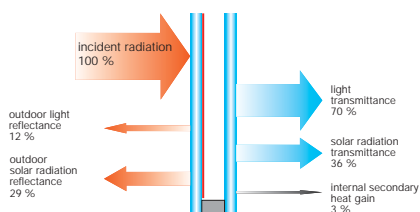

The specified rated values refer to the testing conditions and the application scope of the relevant standard.

## 5 Description of INTERPANE Products



The colour of the outdoor appearance and the intensity of reflected light can be derived from the spectral reflectance values in the visible range from 380 nm to 780 nm.

ipasol  
neutral 73/39

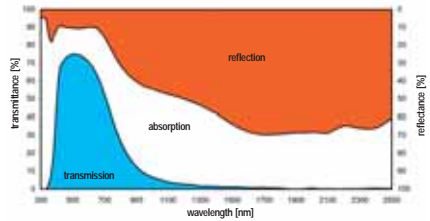
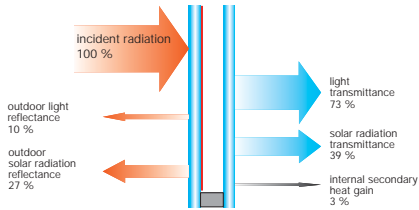

The specified rated values refer to the testing conditions and the application scope of the relevant standard.

## 5 Description of INTERPANE Products



### Delivery programme for ipasol standard solar-control range

Technical data: ipasol															
product name	configuration outer/ space/inner	U <sub>g</sub> value according to EN 673	rated light and solar-radiation properties according to EN						shading coefficient	selectivity factor	thickness	mass	max. dimensions*	max. area	max. ratio of side lengths
			g value	light transmittance	light reflectance outdoors	absorptance outdoors	absorptance indoors	–							
ipasol platin 25/14	6/16/4	1.1	15	25	28	55	0	0.19	1.67	26	25	141 x 240	3.40	1 : 6	
ipasol platin 25/14	8/16/6	1.1	15	24	28	58	1	0.19	1.67	30	35	250/400	8.00	1 : 10	
ipasol shine 40/21	6/16/4	1.1	22	40	16	53	1	0.28	1.82	26	25	141 x 240	3.40	1 : 6	
ipasol shine 40/21	8/16/6	1.1	22	39	16	55	1	0.28	1.82	30	35	250/400	8.00	1 : 10	
ipasol neutral 48/25	6/16/4	1.1	27	48	16	46	1	0.34	1.78	26	25	141 x 240	3.40	1 : 6	
ipasol neutral 48/25	8/16/6	1.1	27	47	16	49	2	0.34	1.74	30	35	250/400	8.00	1 : 10	
ipasol neutral 50/25	6/16/4	1.1	27	50	10	52	1	0.34	1.85	26	25	141 x 240	3.40	1 : 6	
ipasol neutral 50/25	8/16/6	1.1	26	49	10	54	2	0.33	1.81	30	35	250/400	8.00	1 : 10	
ipasol platin 47/28	6/16/4	1.1	30	47	40	29	2	0.38	1.57	26	25	141 x 240	3.40	1 : 6	
ipasol platin 47/28	8/16/6	1.1	29	46	40	33	2	0.36	1.59	30	35	250/400	8.00	1 : 10	
ipasol neutral 60/31	6/16/4	1.1	33	60	11	40	1	0.41	1.82	26	25	141 x 240	3.40	1 : 6	
ipasol neutral 60/31	8/16/6	1.1	32	59	11	43	2	0.40	1.79	30	35	250/400	8.00	1 : 10	
ipasol neutral 68/34	6/16/4	1.1	37	68	10	32	1	0.46	1.84	26	25	141 x 240	3.40	1 : 6	
ipasol neutral 68/34	8/16/6	1.1	36	66	10	35	2	0.45	1.86	30	35	250/400	8.00	1 : 10	
ipasol neutral 70/36	6/16/4	1.1	39	70	12	33	2	0.49	1.79	26	25	141 x 240	3.40	1 : 6	
ipasol neutral 70/36	8/16/6	1.1	38	68	12	36	2	0.48	1.79	30	35	250/400	8.00	1 : 10	
ipasol neutral 73/39	6/16/4	1.1	42	73	10	32	2	0.53	1.74	26	25	141 x 240	3.40	1 : 6	
ipasol neutral 73/39	8/16/6	1.1	41	71	10	36	3	0.51	1.76	30	35	250/400	8.00	1 : 10	

\* Larger dimensions are possible if the glazing configuration is changed.

- ipasol can be combined with ipaphon sound-insulating double glazing, ipasafe thermally toughened, heat-strengthened or laminated glazing and rolled glass. Bullet-resistant glazing is available on request. It is not possible to coat rolled glass and wired glass.
- The customer ordering our products is responsible for ensuring that the glass thickness is dimensioned correctly according to the applicable technical regulations.
- The specified rated values refer to the testing conditions and the application scope of the referenced standard.
- If the energy absorptance in the outer pane exceeds 55 %, we recommend the use of ipasafe thermally toughened safety glass.
- For continuity reasons, the product names for ipasol solar-control glazing are derived from the g value according to DIN 67507. Nevertheless, for energy calculations, the g value according to EN 410 is to be used.

### 5.5.2 ipasol solar-control insulating glazing equipped with sound-insulating properties

Glazing production technology generally allows combination of the ipasol solar-control range with the ipaphon sound-insulating programme.

For combinations of ipasol solar-control glass with ipaphon sound-insulating glazing according to the delivery programme in Section 5.4.3, the requirements on thermal insulation according to energy-saving regulations must be taken into account.

The  $R_W$  value of the standard configuration (6/16/4) is 36 dB, regardless of the ipasol type used. For other sound-insulating combinations, individual tests of the  $U_g$  and  $R_W$  values are recommended already in the planning phase.

The planning criteria listed in Section 5.4.2 are to be observed when ipaphon insulating glazing is used.

In small insulating glass units, i.e. where the edge length is < 50 cm, for gas-filled space widths exceeding 16 mm and/or where the ratio of side lengths is unfavourable, the edge seal is subjected to extremely high loads. If necessary, the thinner pane must be made of thermally toughened glass.

If glass with high absorbance values is used, e.g. body-tinted glass, the gas-filled space width must generally be limited to a maximum of 16 mm. In such cases, use of thermally toughened glass may also be necessary.

The technical data presented refer to the test pane format specified for measurements or calculations in the relevant EN standards.

### 5.5.3 Benefits of ipasol solar-control insulating glazing in sub-tropical regions

To date, single glazing is still being installed in tropical and sub-tropical regions such as Mediterranean countries, South-East Asia or Latin America.

This leads to a restricted architectural style because either body-tinted glass or strongly reflective glazing is used almost exclusively to obtain the solar control needed.

Due to the low light transmittance of such glazing, the indoor rooms are more or less isolated from natural daylight.

Even when the sun is shining outside, the rooms are illuminated with artificial lighting. This artificial lighting only adds to the overheating of the rooms, which is already high due to the high thermal transmission resulting from the lack of thermal insulation.

In addition, if there is a large temperature difference between cooled indoor rooms and hot, humid outdoor air, condensation occurs on the outer glass surface due to the poor  $U_g$  value.

By contrast, ipasol solar-control insulating glazing allows rooms to be lit optimally with natural daylight, as it combines high light transmittance with a low  $g$  value.

The configuration as insulating glazing and the low-emissivity coating on a surface facing the space between the panes ensures that the heat flow from outdoors to indoors is reduced drastically.

Smaller air-conditioning units can thus be chosen before installation and the operating costs decrease significantly.

Lower flow rates of cool air improve comfort and occupant satisfaction increases appreciably.

The insulating glazing configuration improves sound insulation, and disturbing condensation on the outdoor surfaces is largely eliminated.

As the ipasol solar-control coatings are protected by their position within the insulating glass unit, the risk of damage to the coating from the environment or cleaning procedures is almost zero.

### 5.5.4 ipacolor spandrel elements

Spandrel elements offer an architect a distinctive option to clad the external façade of a building entirely with the sophisticated material, glass. By deliberately choosing the spandrel and window elements appropriately, either harmoniously uniform façades or visual accents can be achieved.

Glass as a material also offers many functional benefits.

Glass

- resists weathering
- resists environmental factors
- is durable
- is mechanically stable and
- requires little maintenance.

Two fundamentally different types of façade concepts can be implemented with different constructions: "cold façades" and "warm façades".

A cold façade is constructed with spandrel plates, which consist of single glass panes or double glazed units (insulating glazing).

By contrast, single or double-glazed spandrel panels are used in a warm façade. Spandrel panels consist of spandrel plates which are clad on the back surface with thermally insulating material such as mineral wool or PU foam.

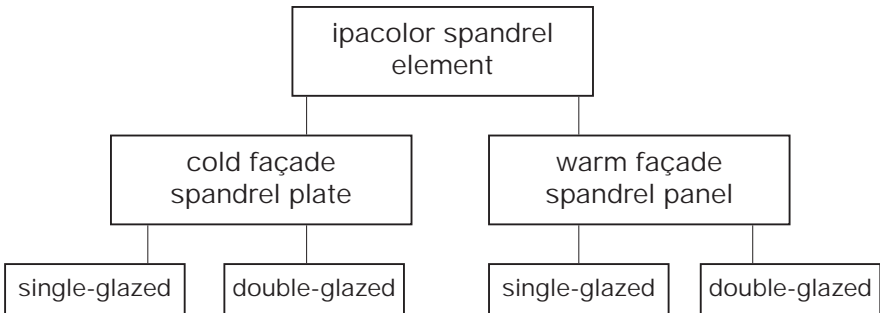

## 5 Description of INTERPANE Products

### a) Cold façade

A cold façade is a two-layer external wall structure with a ventilated space between the layers (see illustration at right).

#### ① Outer layer

The outer layer consists of a single-glazed or double-glazed spandrel plate of thermally toughened glass.

The space in a double-glazed spandrel plate (insulating glass configuration) is generally 6 mm wide.

The outer pane fulfils the functions of

- architectural design
- and
- protection against weathering.

If these spandrel plates are installed with point-formed glazing supports at a height exceeding 8 m, according to German regulations (DIBt) the installation must be supervised by an authorised inspection body according to § 24 c Section 1 No. 5 MBO (German: Musterbauordnung).

#### ② Inner layer

The load-bearing external wall fulfils the functions of

- supporting the glass spandrel plate
- enclosing the indoor space
- and
- thermal insulation.

#### ③ Intermediate space

The space between the outer and inner layer is needed so that

- moisture can be removed by ventilation, preventing damage
- and
- the heat generated after absorption in double-glazed spandrel plates can be removed.

This is important, because the edge seal of insulating glass units is subjected to greater loads if the temperature in the space between the panes is higher.

For single-glazed spandrel plates, the intermediate space for ventilation must be dimensioned according to DIN 18 516 Part 1:

- The distance between the spandrel plate and the wall is  $\geq 20$  mm.
- The cross-sectional area of the inlet and outlet vents is  $\geq 50$  cm<sup>2</sup> per running m.

For double-glazed spandrel plates (insulating glazing), the distance between the spandrel plate and the wall must be  $\geq 30$  mm due to the higher thermal loads.

- The minimal value for the cross-section of the lower inlet vent is 40 % of the pane width x intermediate space thickness (thus  $\geq 120$  cm<sup>2</sup> per running m).
- The minimal value for the cross-section of the upper outlet vent is 50 % of the pane width x intermediate space thickness (thus  $\geq 150$  cm<sup>2</sup> per running m).

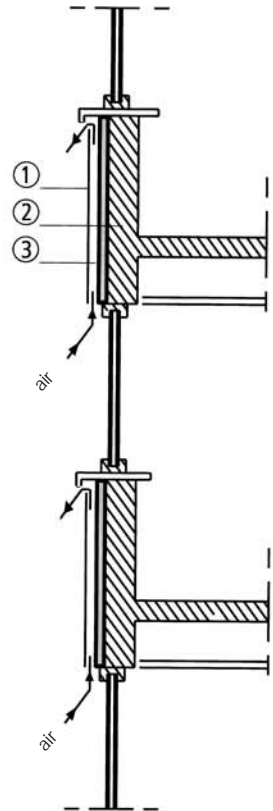

Cold façade

## 5 Description of INTERPANE Products



FCM

### b) Warm façade

A warm façade is a non-ventilated, single-layer external wall structure.

For a warm façade, single-glazed or double-glazed spandrel plates are combined with thermal insulation of the back surface and a moisture barrier toward the room, to form a spandrel panel.

This spandrel panel can then be mounted in the load-bearing façade construction like an insulating glass unit.

In addition to the functions of a spandrel plate in a cold façade, such as

- architectural design
- and
- protection against weathering,

the spandrel panel also fulfils the functions of

- room enclosure
- thermal insulation,
- sound insulation, among others.

However, spandrel panels do not have any load-bearing function.

As there is no rear ventilation in a warm façade, the following essential points must be observed concerning the insulating glass configuration of double-glazed spandrel panels:

- The spandrel panels must be supported on all sides.
- The space between the panes is usually 4 mm wide.
- Both panes must be made of heat-soaked thermally toughened glass (see Section 5.7.1).

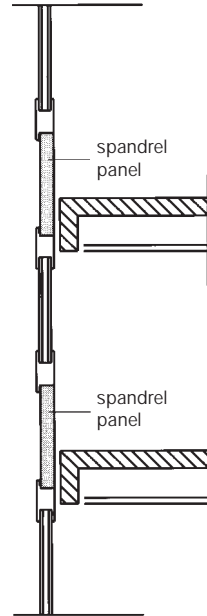

Warm façade

General product specifications of ipacolor spandrel elements











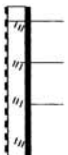

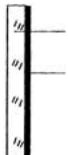

- Spandrel elements are made of heat-soaked thermally toughened glass.
- To dimension the glass thickness, the loads according to DIN 18 516 Part 1 are definitive, unless increased loads result from the specific installation situation. Beyond that, the dimensioning principles of DIN 18 516 Part 4 are to be observed. The thickness of each individual pane may not be less than 6 mm.

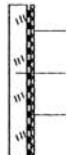
- INTERPANE spandrel elements are normally delivered with bevelled edges.

However, exposed edges of single-glazed spandrel plates should be polished. When single-glazed spandrel plates are ordered, the exposed edges should be specified.

## 5 Description of INTERPANE Products

### Configuration of ipacolor spandrel plates for cold façades

Configuration	Support structure	Further information for installation and glazing
 <ul style="list-style-type: none"> <li> coating</li> <li> heat-soaked thermally toughened glass</li> <li> ceramic frit coating / adhesive film</li> </ul>	<ul style="list-style-type: none"> <li>– on all sides</li> <li>– on two sides</li> <li>– point-formed</li> </ul>	<p>none</p>
 <ul style="list-style-type: none"> <li> heat-soaked thermally toughened glass</li> <li> ceramic frit coating / adhesive film</li> </ul>	<ul style="list-style-type: none"> <li>– on all sides</li> <li>– on two sides</li> <li>– point-formed</li> </ul>	<p>none</p>
 <ul style="list-style-type: none"> <li> adhesive film</li> <li> heat-soaked thermally toughened glass</li> <li> coating</li> </ul>	<ul style="list-style-type: none"> <li>– on all sides</li> </ul>	<ul style="list-style-type: none"> <li>– The film must not be damaged during storage, handling and installation.</li> <li>– If the glass breaks, the glazing system must guarantee that the broken spandrel plate remains in the frame.</li> <li>– If sealants are used for the glazing, their compatibility with the film must be guaranteed.</li> </ul>
 <ul style="list-style-type: none"> <li> coloured layer</li> <li> heat-soaked thermally toughened glass</li> <li> space thickness usually 6 mm</li> </ul>	<ul style="list-style-type: none"> <li>– on all sides</li> <li>– on two sides</li> </ul>	<ul style="list-style-type: none"> <li>– If the spandrel plate is supported on two sides only, the edge seal must be made with suitable silicone.</li> </ul>

# 5 Description of INTERPANE Products



## Configuration of ipacolor spandrel panels for warm façades

FCM

Configuration	Support structure	Further information for installation and glazing installation
	<p>– on all sides</p>	<ul style="list-style-type: none"> <li>– The rebate area must be ventilated.</li> <li>– The rebate area must not be completely filled with sealant.</li> </ul>
		<ul style="list-style-type: none"> <li>– The panel must be installed with the pressure compensation openings at the bottom.</li> <li>– The glazing installation must comply with the INTERPANE glazing guidelines.</li> </ul>

## 5 Description of INTERPANE Products

Building science properties of spandrel panels

Thermal insulation

As the spandrel panel provides the thermal insulation of a warm façade, this property must be dimensioned accordingly.

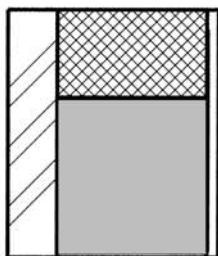

Flush-edged construction

- The thickness of the complete element is thus primarily determined by the required U value and the insulating material used.

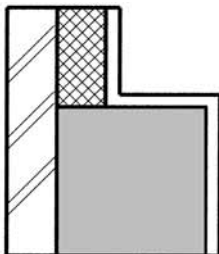

Stepped edge construction

- If the thickness of the panel is greater than the available rebate area, the edge zone of the panel can be made narrower. This allows it to fit into the foreseen rebate.

Sound insulation

By using certain insulating materials in ipacolor spandrel panels, it is also possible to achieve additional sound insulation. However, tests must be made to determine whether the sound reduction index is suitable.

Fire resistance

If fire resistance is specified, non-flammable materials must be used.

Comparison of insulating materials for ipacolor spandrel panels

Physical properties		hard polyurethane foam	mineral wool matting	glass foam
effective density [kg/m <sup>3</sup> ]		30 to 40	≥ 30	125 to 135
pressure resistance [N/mm <sup>2</sup> ]		0.2 to 0.25	compressible	0.5 to 0.7
vapour diffusion resistance factor		≥ 30	≈ 1	∞
thermal conductivity coefficient according to DIN 4108 [W/m <sup>2</sup> K]		0.02 and 0.025	0.035	0.048
application temperature range [°C]		- 180 to + 200	≤ 200	- 260 to + 430
water absorption		none	possible	none
fire-related properties		B 1, B 2 and B 3	non-flammable building component category A 1 u. A 2	non-flammable building component category A 1
thermal transmittance (U value) in W/m <sup>2</sup> K for different thicknesses of the insulating materials	thickness [mm]			
	25	0.70	1.13	1.45
	40	0.46	0.76	1.00
	45	0.41	0.69	0.90
	50	0.37	0.63	0.83
	60	0.32	0.53	0.70
	80	-	0.41	0.54
100	-	0.33	0.44	

## 5 Description of INTERPANE Products



Correlation of the deliverable ipacolor spandrel elements to the INTERPANE product range of insulating glazing

Spandrel elements are used mainly in prestigious buildings in combination with ipasol solar-control glazing.

However, it is also possible to combine them with iplus E low-e coated glazing.

The following table presents recommendations for colour-matched spandrel elements.

Optimised colour matching between insulating glazing and spandrel elements can be achieved with double-glazed configurations. Nevertheless, the complete façade element should be assessed on site if possible, to judge whether the overall effect is harmonious.

Delivery programme for ipacolor spandrel elements

Insulating glass unit		Standard recommendation for colour-matched spandrel elements *)		
		single glazing		double glazing
		ceramic frit	adhesive film	ceramic frit or adhesive film
ipasol solar-control glazing	platin 25/14	–	–	9039
	shine 40/21	1025	4401	9035
	neutral 48/25	–	–	9041
	neutral 50/25	2009	4301	9031
	platin 47/28	1500	4500	9029
	neutral 60/31	–	–	9038
	neutral 68/34	5161	4405	9028
	neutral 70/36	–	–	9037
	neutral 73/39	2010	–	9030
low-e glazing	iplus neutral E	5101	–	9034
climate glazing	iplus sun	2010	–	9032

\*) The intended application (cold façade or warm façade) should be specified with the order.

### 5.6 Conventional double glazing

Conventional double glazing with the  $U_g$  value of 2.9 W/m<sup>2</sup>K according to EN 673 no longer meets modern demands regarding ecology and economy.

Due to the more stringent specifications, conventional double glazing finds only restricted use today.

The thermally insulating effect of uncoated double glazing is determined essentially by the insulating effect of the air in the space between the panes.

The U value of the double glazed unit depends primarily on the thickness of this space and only secondarily on the thickness of the individual panes.

### Delivery programme for uncoated double glazing

#### Technical data: uncoated double glazing

product name	configuration outer/ space/inner	U <sub>g</sub> value according to EN 673	rated light and solar-radiation properties according to EN 410			thickness	mass	max. dimensions	max. area	max. ratio of side lengths
			g value	light transmittance	general colour rendering index in transmission					
	mm	W/m <sup>2</sup> K	%	%	–	mm	kg/m <sup>2</sup>	cm	m <sup>2</sup>	–
conventional double glazing	4/12/4	2.9	77	82	98	20	20	141 x 240	3.40	1 : 6
conventional double glazing	5/12/5	2.8	75	80	97	22	25	245 / 300	6.00	1 : 6
conventional double glazing	6/12/6	2.8	72	79	96	24	30	250 / 400	8.00	1 : 10

- The customer ordering our products is responsible for ensuring that the glass thickness is dimensioned correctly according to the applicable technical regulations.
- The specified rated values refer to the testing conditions and the application scope of the referenced standard.

## 5 Description of INTERPANE Products





# **INTERPANE**

*GLASS FOR LIFE*

Safety aspects and glass as a structural building component are increasingly important issues today.

INTERPANE produces high-quality safety glass products such as thermally toughened glass, heat-strengthened glass and laminated safety glass at various locations.

### 5.7 ipasafe safety glass

Glass building components are a distinctive feature of modern architecture. The possibility of using glass as a load-bearing component motivates architects, planners and engineers to implement increasingly daring designs. The response to this challenge has been the development of glazing types which combine active, passive and mechanical safety aspects.

Active safety means:

- protection against burglary, shooting and damage to life and limb

Passive safety means:

- protection against injury caused by glass as a material

Mechanical safety (in a building) means:

- residual structural stability and
- residual structural strength

in the case of damage (see Section 5.7.2).

Two main types of safety glass can be distinguished:

- laminated safety glass and
- thermally toughened safety glass

In addition to classic thermally toughened safety glass, so-called "heat-strengthened" glass has thermal and mechanical properties which lie between those of float glass and thermally toughened safety glass (see Section 5.7.2). Heat-strengthened glass is not safety glass according to the conventional definition.

CE labelling

ipasafe safety glass fulfils the requirements of

- EN 12 150, Part 2 for thermally toughened safety glass
- EN 1863, Part 2 for heat-strengthened glass
- EN 14 179, Part 2 for heat-soaked thermally toughened glass
- EN 14 49, Part 2 for laminated safety glass

The CE label confirms compliance of the product with the requirements of the applicable standards (see also Section 5.1, CE Labelling).

German "Ü" symbol

All types of ipasafe safety glass conform to the requirements of the German building regulation list (BRL-A).

Each Ü symbol confirms the conformity of the product with the relevant requirements of the German building regulation list (BRL-A).

## 5 Description of INTERPANE Products



### 5.7.1 Thermally toughened safety glass

Product description of thermally toughened safety glass according to EN 12 150

Thermally toughened safety glass is glass in which a permanent surface compressive stress has been induced by thermal treat-

ment. The actual production process for thermally toughened glass consists of rapid and homogeneous heating of a glass pane to a temperature above 600 °C and subsequent rapid cooling (annealing) by blowing cold air onto the pane.

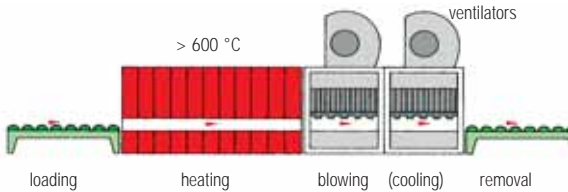

Generation of the internal stress in thermally toughened safety glass

The specific thermal conductivity of glass ensures that the outer zones of the pane quickly solidify when it is cooled rapidly. As the core of the pane cools, it contracts. This contraction process

is hindered by the already solidified outer zones. The characteristic stress distribution of thermally toughened safety glass results, with the outer surfaces being under compressive stress toward the core, whereas the core of the pane is subjected to tensile stress as cooling proceeds.

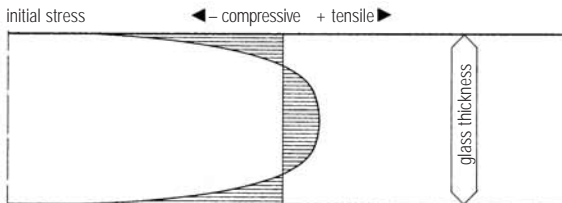

Both types of stress must be in equilibrium with each other, as this is the only way to achieve the stable stress condition which guarantees the safety properties of thermally toughened safety glass.

As part of the initial type testing and factory production control, the two essential properties of thermally toughened safety glass according to EN 12 150 are tested:

- **Fragmentation structure:** If the stress equilibrium is destroyed and breakage occurs, a fine network of small, mainly blunt-edged glass pieces must form. This significantly reduces the risk of injury.
- **Mechanical strength:** (bending tensile strength): 120 N/mm<sup>2</sup> (thermally toughened safety glass made of float glass), compared to 45 N/mm<sup>2</sup> for normal float glass.

In addition to these properties relevant to safety, thermally toughened safety glass also features other advantages:

- **Greater resistance to impact:** Pendulum test according to EN 12 600
- **Greater resistance to temperature differences:** Thermally toughened safety glass is resistant to temperature differences of up to 200 K over the pane area. Normal float glass is much more sensitive to temperature differences (40 K).

## 5 Description of INTERPANE Products



Heat-soaked thermally toughened safety glass

- a) Product description for heat-soaked thermally toughened safety glass according to EN 14179

Heat-soaked thermally toughened safety glass is glass in which a permanent surface compressive stress has been induced by thermal treatment. The actual production process for thermally toughened glass consists of rapid and homogeneous heating of a glass pane to a temperature above 600 °C and subsequent rapid cooling (annealing) by blowing cold air onto the pane. Subsequently, the glass pane is heat-soaked at 290 °C ± 10 °C to minimise the risk of spontaneous breakage.

Delayed breakage of thermally toughened glass panes without apparent application of any external force is called spontaneous breakage. Spontaneous breakage should not be confused with delayed breakage which is caused by mechanical forces or subsequent damage to the edges. Inappropriate transport and incorrect further processing can also lead to breakage.

In a heat-soak test, possible spontaneous breakage is deliberately induced by heating the pane.

The EN 14 179 standard has been recognised as a harmonised European product standard by publication in the official gazette of the European Union. However, the German building regulation list (BRL) specifies further requirements for the application of heat-soaked thermally toughened glass.

### Criteria for calibration

In calibrated heat-soak furnaces at the INTERPANE factory, all parts of the glass pane are subjected at all positions to a temperature of 290 °C ± 10 °C for a duration of at least 2 hours. The heat-soak test specified in the German building regulations list has a duration of at least 4 hours.

The heat-soaking process must follow the illustrated time-temperature profile. The system must be capable of following this profile both when the furnace is fully loaded and when it has a partial load of only 10 %.

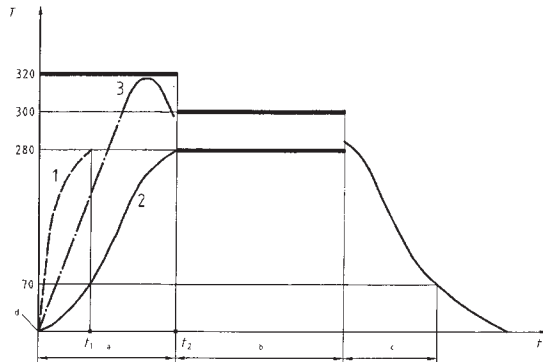

- Legend
- T glass temperature at every position, °C
  - t time, h
  - $t_1$  point in time when the first glass pane reaches 280 °C
  - $t_2$  point in time when the last glass pane reaches 280 °C
  - 1 first glass pane to reach 280 °C
  - 2 last glass pane to reach 280 °C
  - 3 glass temperature
  - d ambient temperature
  - a heating phase
  - b soaking phase
  - c cooling phase

Time-temperature profile as a calibration criterion

A heat-soak test complying with the regulations minimises the risk of spontaneous breakage after installation due to nickel sulphide inclusions, according to the current state of the art.

## 5 Description of INTERPANE Products



As part of the initial type testing and factory production control, the two essential properties of heat-soaked thermally toughened safety glass according to EN 14 179 are tested:

- Fragmentation structure: If the stress equilibrium is destroyed and breakage occurs, a fine network of small, mainly blunt-edged glass pieces must form. This significantly reduces the risk of injury.
- Mechanical strength: (bending tensile strength): 120 N/mm<sup>2</sup> (heat-soaked thermally toughened safety glass made of float glass), compared to 45 N/mm<sup>2</sup> for normal float glass.

In addition to these properties relevant to safety, heat-soaked thermally toughened safety glass also features other advantages:

- Greater resistance to impact: Pendulum test according to EN 12 600
- Greater resistance to temperature differences: Thermally toughened safety glass is resistant to temperature differences of up to 200 K over the pane area. Normal float glass is much more sensitive to temperature differences (40 K).

- b) Heat-soaked thermally toughened safety glass according to the German building regulations list A (BRL-A), Part 1

For applications where the German Technical Building Code specifies heat-soaked thermally toughened safety glass, heat-soaked thermally toughened soda lime silicate safety glass which is subject to third-party surveillance must be used according to the conditions of the German building regulation list BRL-A, Part 1, Nr. 11.13, Appendix 11.11.

From now on, heat-soaked thermally toughened safety glass subject to third-party surveillance must always be used when thermally toughened safety glass is required, unless the glazing is not adjacent to spaces where people can be present (circulation spaces) and is mounted at a height of less than 4 m.

This is a consequence of the technical regulations for applications of linearly supported glazing in combination with the list of the German Technical Building Code.

## 5 Description of INTERPANE Products



Application areas for thermally toughened safety glass and heat-soaked thermally toughened safety glass

- Residential and commercial buildings for stairwells, doors, automatic door systems and glass dividing walls

For exterior glazing which is one storey high, e.g. outdoor sliding doors, thermally toughened glass is urgently recommended for safety reasons!

- Sport buildings resistant to ball impact according to DIN 18 032, Parts 1 and 3
- School and kindergarten buildings for safety reasons to avoid injury

- Near heaters to prevent breakage due to thermal stress

If a heater is less than 30 cm away from a glazing unit, thermally toughened glass should be used for the interior pane - see INTERPANE's glazing guidelines, Section 6.4.1

- Completely glazed façades  
The spandrel glazing used as façade cladding must comply with DIN 18516, Part 4 (Requirements and testing).
- Banisters and balustrades  
Glass is used in banisters and balustrades to prevent injury due to falling off stairs and balconies. The German "Technical regulations for application of glazing to prevent falling" define the possibilities for applying thermally toughened safety glass in balustrades

(Section 7.7.3). Proof of the impact resistance of thermally toughened safety glass is to be provided by pendulum tests according to EN 12 600. The requirements of the relevant national building regulations must be observed.

- Outdoor applications  
noise reduction walls along roads and railway lines, bus shelters, showroom windows and show cases.

Test report for ipasafe on resistance to ball impact  
 Thermally toughened safety glass 6 mm  
 max. dimensions: 1200 mm x 1800 mm  
 The validity of the test report is regularly renewed  
 with unchanged content.





**MPA**  
 MPA STUTTGART  
 One-Contact-Unit  
 Messungsinstrumente • Universität Stuttgart

071 1 695-2729  
 0711 695-2785  
 Johannes.Schmid@ip-onecontact.de  
 Prof. Dr. Jochen Böhm, Stornastr. 10a  
 Jochen.Böhm

Telefon:  
 Telefax:  
 E-Mail:  
 Fachbereichsleitung:  
 Sachverständiger

Messprüfungsstelle: Otto-Graf-Institut Universität Stuttgart • D-70560 Stuttgart  
 31135 Hildesheim

**Prüfzeugnis**  
**INTERPANE Sicherheitsglas GmbH & Co**  
 31135 Hildesheim  
**Prüfung der Ballwurfsicherheit**  
 nach DIN 18 032 Teil 3 Ausgabe April 1997

Datum des Prüfzeugnisses : 19.08.2003  
 Auftrag : 46/903 649/SmC  
 Textzeilen : 3  
 Beilagen : 1

Die letzte Textzeile und die Beilagen sind mit unserem Dienststempel versehen. Die Vervielfältigung und Veröffentlichung dieses Dokumentes in gekürztem Wortlaut sowie die Verwendung zur Werbung ist nur mit unserer schriftlichen Genehmigung und Erlaubnis der Universität Stuttgart.

Seite 1 von 4 Seiten



**MPA**  
 MPA STUTTGART  
 One-Contact-Unit

Prüfzeugnis 46/903 649  
 vom 19.08.2003

**INTERPANE Sicherheitsglas GmbH & Co**  
 Maybachstraße 5  
 31135 Hildesheim

Unsere Zeichen : 46/903 649/SmC  
 Betreff : Prüfung der Ballwurfsicherheit  
 nach DIN 18 032 Teil 3

Wir wurden von der Fa. INTERPANE (Hildesheim) beauftragt, ein Verglasungselement auf Ballwurfsicherheit entsprechend der DIN 18032 Teil 3 „Sporthallen, Hallen für Turnen und Spiele und Mehrzwecknutzung; Prüfung der Ballwurfsicherheit“ Ausgabe April 1997 zu prüfen.

Dazu brachte die Firma das zu prüfende Element am 26.06.2003 in unserem Ballschußprüfstand an.

**1. Beschreibung des Einbauelements**

Bei dem untersuchten Einbauelement handelte es sich um die Sporthallenverglasung „**ipasafe ESG 6 mm**“

Das Verglasungselement hatte die Abmessungen 1800 mm x 1200 mm und bestand aus einer 6 mm dicken ESG-Verglasung.

Zur Prüfung war das Einbauelement in einen Holzrahmen eingelegt. Zwischen Holzrahmen und Scheibe war rundum ein Schaumstoffklebeband eingelegt.

Seite 2 von 4 Seiten

Test report for ipasafe on resistance to ball impact  
 Thermally toughened safety glass 6 mm  
 max. dimensions: 1200 mm x 1800 mm  
 The validity of the test report is regularly renewed  
 with unchanged content.



**2. Durchführung der Prüfung**

Die Prüfung erfolgte nach DIN 18 032 Teil 3 „Sporthallen, Hallen für Turnen und Spiele und Mehrzwecknutzung, Prüfung der Ballwurfsicherheit“ -Ausgabe April 1997.

Die Prüfung erfolgte bei Raumtemperatur im Labor.

**3. Prüfungsergebnis**

Ball	Auftreffwinkel in Grad	Anzahl der Schüsse	Veränderungen am Einbauelement
Handball	90	30	
Handball	45	12	
Handball	45	12	
Hockeyball	90	4	keine
Hockeyball	45	4	
Hockeyball	45	4	

Das geprüfte Einbauelement überstand die Beanspruchung ohne Schäden. Es erwies sich somit als ballwurfsicher nach DIN 18 032 Teil 3 für den Anwendungsbereich Decke.

Dieser Prüfnachweis ist gültig bis zum 19.08.2005.

Eine Wiederholungsprüfung ist zu diesem Zeitpunkt nur dann nicht erforderlich, wenn der Antragsteller nachweist und sich vom Prüfinstitut bestätigen läßt, daß das geprüfte Einbauelement in den wesentlichen Teilen unverändert produziert und eingebaut wird.



*C. Schmid*  
 Schmitt  
 Sachbearbeiter

*i. A. Schenk*  
 Dipl.-Ing. Knaut  
 Referatsleiter



Gesamtansicht:  
 Sporthallenverglasung  
 -ipasafe ESG 6 mm

**Interpane Sicherheitsglas GmbH & Co KG**  
Maybachstraße 5

31135 Hildesheim

**Unsere Zeichen:** 55150/900 8060/Sc/C

**Betreff:** : Prüfung der Ballwurfsicherheit  
nach DIN 18 032 Teil 3

Wir wurden von der Fa. Interpane (Hildesheim) beauftragt, ein Verglasungselement auf Ballwurfsicherheit entsprechend der DIN 18032 Teil 3 „Sporthallen, Hallen für Turnen und Spiele und Mehrzwecknutzung; Prüfung der Ballwurfsicherheit“ Ausgabe April 1987 zu prüfen.

Dazu brachte die Firma das zu prüfende Element am 08.07.2004 in unserem Ballschulprüfstand an.

#### 1. Beschreibung des Einbauelements

Bei dem untersuchten Einbauelement handelte es sich um die Sporthallenverglasung

„ipasafe ESG 8 mm“

Das Verglasungselement hatte die Abmessungen 2100 mm x 3600 mm und bestand aus einer 8 mm dicken Einschleissicherheitsverglasung.

Zur Prüfung war das Einbauelement in einen Holzrahmen eingelegt.

Zwischen Holzrahmen und Scheibe war rundum beidseitig ein Schaumstoffklebeband eingelegt.

Test report for ipasafe on resistance to ball impact  
Thermally toughened safety glass 8 mm  
max. dimensions: 2100 mm x 3600 mm  
The validity of the test report is regularly renewed  
with unchanged content.

#### Prüfzeugnis

Interpane Sicherheitsglas GmbH & Co KG  
31135 Hildesheim

Prüfung der Ballwurfsicherheit  
nach DIN 18 032 Teil 3 Ausgabe April 1997

Datum des Prüfzeugnisses : 05.08.2004  
Auftrag : 55150/900 8060/Sc/C  
Textseiten : 3  
Beilagen : 1

**Test report for ipasafe on resistance to ball impact**  
**Thermally toughened safety glass 8 mm**  
**max. dimensions: 2100 mm x 3600 mm**  
**The validity of the test report is regularly renewed**  
**with unchanged content.**



**MPA** MPA STUTTGART  
 One-Partnerstatut

Prüfzeugnis 551 50/900 0090

vom 05.08.2004

Beilage 1

**MPA** MPA STUTTGART  
 One-Partnerstatut

Prüfzeugnis 551 50/900 0090

vom 05.08.2004

**2. Durchführung der Prüfung**

Die Prüfung erfolgte nach DIN 18 032 Teil 3 „Sporthallen, Hallen für Turnen und Spiele und Mehrzwecknutzung, Prüfung der Ballwurfsicherheit“ Ausgabe April 1997.

Die Prüfung erfolgte bei Raumtemperatur im Labor.

**3. Prüfungsergebnis**

Ball	Aufschlagwinkel in Grad	Anzahl der Schläge	Veränderungen am Einbauelement
Handball	90	30	
Handball	45	12	
Handball	45	12	
Hockeyball	90	4	
Hockeyball	45	4	
Hockeyball	45	4	keine

Das geprüfte Einbauelement überstand die Beanspruchung ohne Schäden. Es erwies sich somit als ballwurfsicher nach DIN 18 032 Teil 3.

Detailsicht:  
 Sporthallenverglasung  
 ipasafe ESG 8 mm



**Dieser Prüfnachweis ist gültig bis zum 05.08.2006.**

Eine Wiederholungsprüfung ist zu diesem Zeitpunkt nur dann erforderlich, wenn der Antragsteller nachweist und sich vom Prüfinstitut bestätigen läßt, daß das geprüfte Einbauelement in den wesentlichen Teilen unverändert produziert und eingebaut wird.



*Gid*  
 Schmid  
 Sachbearbeiter

*J. A. Knäuf*  
 Dipl.-Ing. Knäuf  
 Referatsleiter

## 5 Description of INTERPANE Products



Processing options for thermally toughened safety glass

The generated stress distribution in the thermally toughened safety glass means that subsequent processing such as cutting, drilling or similar machining is no longer possible. Even disturbance of the surface tension leads to destruction of the pane. Thus, all processing must be carried out before the thermal toughening process.

### a) Edge finishing

Every glass pane which is to be thermally toughened must be edge-finished prior to toughening. For the production technology, the edges must be at least arrissed.

- Arrissed  
An arrissed edge corresponds to a cut edge which has been bevelled to some extent by a grinding tool.
- Ground  
The glass pane is machined to the required dimensions by grinding the edges. The ground edges can have broken borders (corresponding to an arrissed edge). Blank spots and conchoidal fractures are permissible.

- Smooth ground  
The whole area of the edge is ground. The borders are bevelled by grinding. Smooth ground edges appear matt. Blank spots and conchoidal fractures are not permissible.
- Polished  
The polished edge is a ground edge which has been further finished by polishing. Polishing traces are permissible to a certain extent.
- Bevel edge

A bevel edge forms an angle  $\alpha$  to the glass surface, where  $45^\circ \leq \alpha \leq 90^\circ$ .

The edges can be "smooth ground" or "polished".

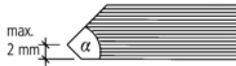

The edges are finished either manually or with machines, depending on the length of the edge and the shape of the pane.

For panes which must be at least partially manually edge-finished, we recommend manual edge finishing around the entire perimeter for optical reasons. Technical clarification is necessary for each specific case.

### b) Cant corners

The production technology requires that custom-shaped panes with acute angles of  $< 30^\circ$  be cut back.

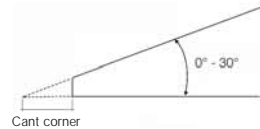

## 5 Description of INTERPANE Products



c) Holes, notches and cut-outs at corners and along edges

A, B = separation distance  
 D = hole diameter  
 K = edge length  
 S = glass thickness

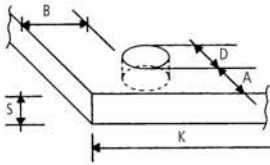

- The diameter of the hole or the width of the notch must be greater than or equal to the glass thickness:

$$D \geq S$$

- The distance of a hole or notch from the glass edge may not be less than half the diameter

$$A \geq \frac{D}{2}$$

The distance from the edge to the hole or notch may be smaller than the minimum specified

above only if a stress-relieving cut is made and the hole diameter is  $\geq 1.5$  times the glass thickness:

$$D \geq 1.5 S$$

The same criteria apply for the distance between two holes as between a hole and the edge of the glass pane.

The diameter of a notch may not be greater than 1/3 of the affected pane edge length:

$$D \leq K/3$$

The following tolerances apply for the diameter of a hole or notch:

$$D \leq 120 \text{ mm: } \pm 1.0 \text{ mm}$$

$$D > 120 \text{ mm: } \pm 2.0 \text{ mm}$$

Tolerances on the positions of holes

Tolerances for holes and notches are determined by the production process. In general, the tolerances for the width and length of holes and notches cor-

respond to the values tabulated on the next page.

The hole diameter should be at least 4 mm larger than the bolt diameter due to the sleeve which must be used around the bolt. The diameter of the hole or notch should be dimensioned such that the effect of tolerances on distances can be compensated.

If more than four holes form a group, the minimum distance between the holes must be larger.

- Cut-outs along the edge or at corners must have a radius which is greater than or equal to the glass thickness, and must be at least 10 mm. The cut-outs should be dimensioned such that the effect of tolerances on distances can be compensated. The cut-out diameter may not be longer than one third of the pane edge.

position of hole	S < 8 mm		S ≥ 8 mm	
	D ≥ 1.5 S	S ≤ D < 1.5 S	D ≥ 1.5 S	S ≤ D < 1.5 S
edge zone – distance to an edge	A ≥ 2 S	A ≥ 2 S	A ≥ 2.5 S	A ≥ 2.5 S
corner zone – distance to two edges	A ≥ 2 S + 5 mm B ≥ 2 S + 5 mm	A ≥ 5 S B ≥ 2 S + 5 mm	A ≥ 2.5 S + 5 mm B ≥ 2.5 S + 5 mm	A ≥ 5 S B ≥ 2.5 S + 5 mm

## 5 Description of INTERPANE Products



Requirements on the quality of thermally toughened safety glass

### a) Scope

These quality criteria apply to flat, thermally toughened safety glass for use in buildings and constructions.

The following basic products are used to produce thermally toughened safety glass:

- Glass: – float glass EN 572, Part 2  
 – patterned glass (cast glass) EN 572, Part 5

The glass can be

- colourless or coloured
- transparent, translucent, opaque or opalescent
- coated or enamelled (ceramic)
- surface-treated, e.g. sand-blasted or etched.

### b) Tolerances

Nominal thicknesses and tolerances for basic products according to EN 12150, Part 1

nominal thickness in mm	tolerances in mm	
	float glass	patterned glass
–		
4	± 0.2	± 0.5
5		
6		
8	± 0.3	± 0.8
10		± 1.0
12		–
15	± 0.5	–
19	± 1.0	–

Tolerances on the width (B) and length (H) derived from EN 12 150, Part 1

Length H or width B of the glass edge	absolute tolerance nominal thickness ≤ 12 mm	absolute tolerance nominal thickness > 12 mm
up to 500 mm	± 1.0 mm	± 2.0 mm
up to 1000 mm	± 1.5 mm	± 2.0 mm
up to 2000 mm	± 2.0 mm	± 2.5 mm
up to 3000 mm	± 2.5 mm	± 3.0 mm
up to 3500 mm	± 3.0 mm	± 4.0 mm
more than 3500 mm	± 3.5 mm	± 5.0 mm

Thermally toughened safety glass for coating

The quality criteria concerning tolerances, flatness, etc. may be stricter for thermally toughened safety glass products which are to be coated. INTERPANE should be consulted prior to ordering.

### Flatness

The deviation from flatness depends on the thickness, the dimensions and the ratio of edge lengths of a pane. The deformation is known as bow. Two types of bow are distinguished: overall or general bow, and local bow.

#### Overall or general bow ( $t_G$ )

The glass pane is placed at room temperature in a vertical position and supported on its longer side by two load-bearing blocks at the quarter points.

The deformation is measured as the maximum distance  $h_1$  from a straight metal ruler or a stretched wire to the concave surface of the glass (see figure). It is measured along the edges of the glass and along the diagonals.

In all cases, the value for overall bow is expressed as the ratio of the deformation  $h_1$  to the measured length of the edge of the glass (B or H as applicable) or the diagonal.

$$t_G = \frac{h_1}{B \text{ or } H} \left[ \frac{\text{mm}}{\text{m}} \right]$$

#### Local bow ( $t_0$ )

Local bow is measured over a limited length of 300 mm by using a straight ruler, or a stretched wire (see figure). It is expressed as the ratio of the distance  $h_2$  to a length of 300 mm:

$$t_0 = \frac{h_2}{300} \left[ \frac{\text{mm}}{\text{mm}} \right]$$

For patterned glass, local bow is determined by using a straight ruler resting on the high points of the pattern and measuring to a high point of the pattern.

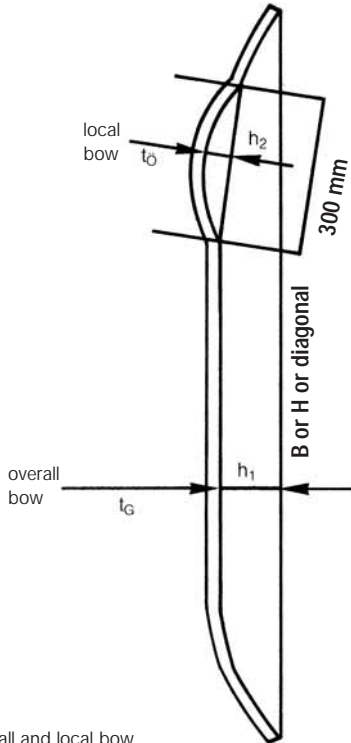

Overall and local bow

Maximum values for overall and local bow derived from EN 12 150, Part 1				
type of glass	glass thickness [mm]	maximum values for		
		overall bow [mm/m]	local bow [mm/300 mm]	
thermally toughened safety glass made of	float glass	4 - 19	3*	0.3
	patterned glass	4 - 10	4	0.5

\* For square and nearly square formats with a ratio of side lengths between 1:1 and 1:1.3, the deviation from flatness is inevitably greater than for narrower rectangular formats. Particularly for glass thicknesses  $\leq 6$  mm, INTERPANE should be consulted before ordering.

## 5 Description of INTERPANE Products



### c) Deviations in pattern and colour

It is fundamentally impossible to guarantee that the structure of several adjacent panes of patterned glass will be symmetric.

The direction of a pattern should be specified in the order. If this specification is missing, the glass pane will be produced with the direction of the pattern parallel to the pane height.

For reasons relating to the production technology, shifts in the design and slight colour differences are possible with patterned glass and coloured glass.

### d) Tests

Within the framework of the factory production control and third-party surveillance, the production of ipasafe thermally toughened glass is regularly tested in accordance with the relevant standards.

Fragmentation structure according to EN 12 150, Part 1.

Count values and dimensions of particles

type of glass		nominal thickness [mm]	minimum particle count	max. length of longest particle [mm]
thermally toughened safety glass made of	float glass	4 – 12	40	100
	float glass	15 – 19	30	100
	patterned glass	4 – 10	30	100
dimensions of counting template: 50 mm x 50 mm				

Mechanical strength (bending tensile strength) according to EN 1288, Part 3 / EN 12 150, Part 1

type of glass		nominal thickness [mm]	mechanical strength (bending tensile strength**) [N/mm <sup>2</sup> ]
thermally toughened safety glass made of	float glass	4 – 19	120
	patterned glass	4 – 10	90
	enamelled float glass	4 – 19	75 *)
*) ceramic-coated surface in tension			
**) The mechanical strength value (bending tensile strength) is defined as the minimum quasi-static bending load for which a lower confidence limit of 95 % leads to a 5 % probability of breakage.			

Pendulum test according to EN 12 600.

## 5 Description of INTERPANE Products



71

### e) Visual assessment of quality

The testing principles and relevant tables for visual assessment are defined in the "Guideline to assess the visual quality of architectural glazing", published in Section 7.7.5.

The permissibility of deviations which are observed during these tests is decided according to these testing principles and tables.

### f) Physical characteristics

#### Optical features

As the glass lies on rollers in the furnace during the thermal toughening process, slight changes in the surface can occur occasionally. These so-called "roller waves" are caused by physical processes and cannot always be avoided. In the individual case, they can cause a slight distortion of the reflected image.

The thermal toughening process can also cause chemical and mechanical changes in the surface structure such as small spots ("roller pick-up") and roller impressions.

#### Anisotropy

Anisotropic iridescent effects can be observed on thermally toughened safety glass. A detailed explanation of these effects can be found in Section 4.12.

### Thermal durability

The mechanical properties of thermally toughened safety glass are unchanged for application temperatures up to 250 °C. Thermally toughened safety glass can resist both sudden temperature changes and temperature differences across the pane surface of up to 200 K.

### Wettability of the glass surface by moisture

The wettability of the glass surface can vary due to the effect of traces from rollers, fingerprints, labels, paper grain, vacuum suction cups, slurries or lubricants.

If the glass surfaces are moistened by condensation, rain or cleaning water, the differing wettability can become evident. These effects are typical characteristics and do not provide a reason for reclamation.

### g) Marking

Every pane of ipasafe thermally toughened safety glass is permanently marked at least with "EN 12 150" and the name or logo of the manufacturer. According to this standard, the marking must be indelible.

Similarly, every pane of ipasafe heat-soaked thermally toughened safety glass is permanently marked at least with "EN 14 179" and the name or logo of the manufacturer.

The permanent, easily visible marking of ipasafe heat-soaked thermally toughened safety glass according to the German building regulation list (BRL) includes the following specifications:

- manufacturer or factory
- ESG-H
- certification body.

## 5 Description of INTERPANE Products



### Delivery programme for thermally toughened safety glass

max. dimensions in cm for ipasafe thermally toughened safety glass (with or without heat soaking)									
type of glass	colour	glass thickness / dimensions							
		4 mm	5 mm	6 mm	8 mm	10 mm	12 mm	15 mm	19 mm
float glass	clear	150x250	200x300	260x450	260x450	260x450	260 / 450	260 / 450	260 / 450
float glass	blue	-	-	200x300	200x300	200x300	-	-	-
float glass	bronze	150x250	200x300	260x450	260x450	260x450	260 / 450	-	-
float glass	grey	150x250	200x300	260x450	260x450	260x450	260 / 450	-	-
float glass	green	150x250	200x300	260x450	260x450	260x450	-	-	-
translucent glass	translucent	150x250	200x300	260x450	260x450	260x450	260 / 450	260 / 450	-
satin-finished glass	translucent	200x300	200x300	200x300	260x450	260x450	200x300	-	-
Antelio silver	clear	-	-	260x450	200x300	-	-	-	-
Stopsol super silver	clear	-	-	260x450	200x300	200x300	-	-	-
Gothic	translucent	70x150	-	-	-	-	-	-	-
Ornament 504	translucent	100x200	-	-	-	-	-	-	-
SR Barock	translucent	70x150	-	-	180x400	-	-	-	-
SR Chinchilla	translucent	100x200	-	180x360	180x400	-	-	-	-
SR Lustral	translucent	-	-	180x360	180x400	180x400	-	-	-
SR Madera 176	translucent	-	-	-	180x400	-	-	-	-
SR Mastercarre	translucent	100x200	-	180x300	180x300	200x320	-	-	-
SR Masterligne	translucent	100x200	-	180x300	180x300	-	-	-	-
SR Masterpoint	translucent	100x200	-	180x300	180x300	-	-	-	-
SR Silvit 178	translucent	100x200	-	180x360	180x400	180x400	-	-	-
Gothic	bronze	70x150	-	-	-	-	-	-	-
SR Barock	bronze	70x150	-	-	-	-	-	-	-
SR Chinchilla	bronze	100x200	-	-	180x400	-	-	-	-
SR Silvit 178	bronze	100x200	-	-	180x400	-	-	-	-

Dimensions up to 600 cm are available on request.

Minimum dimensions: 20 cm x 30 cm for rectangular ipasafe thermally toughened safety glass  
 Minimum diameter: 30 cm  
 Maximum ratio of side lengths: 1 : 10  
 Maximum mass: 350 kg per glazing unit

- For square and nearly square formats with a ratio of side lengths between 1:1 and 1:1.3, the deviation from flatness is inevitably greater than for narrower rectangular formats. Particularly for glass thicknesses  $\leq 6$  mm, INTERPANE should be consulted before ordering.

E 71

## 5 Description of INTERPANE Products



### 5.7.2 Heat-strengthened glass

Product description of heat-strengthened glass according to EN 1863

Heat-strengthened glass is produced with a similar production process to thermally toughened safety glass.

The difference is that after being heated quickly and homogeneously to over 600 °C (as for thermally toughened safety glass), the glass pane is cooled much more gradually by ventilation with cold air. The thermal treatment induces a permanent surface compressive stress in the glass, which then has a significantly higher resistance to thermal and mechanical loads than float glass.

The essential characteristics of heat-strengthened glass are tested as part of the initial type testing and in the ongoing factory production control.

- The mechanical strength (bending tensile strength) of 70 N/mm<sup>2</sup> is between the values for untreated float glass and thermally toughened safety glass made of float glass.
- The fragmentation structure of a single pane is similar to that of normal float glass. For this reason, heat-strengthened glass is not safety glass.

As the degree of thermal stress in the strengthening process is relatively low, spontaneous breakage due to nickel sulphide inclusion can practically be ruled out. Thus, the heat soak test is not necessary.

Heat-strengthened glass should be preferred to thermally toughened safety glass if greater mechanical strength and resistance to temperature differences than for normal float glass are needed, but the resi-

dual self-support after damage to thermally toughened safety glass is too small, due to the large number of small particles.

However, the main use of heat-strengthened glass is as a component of laminated safety glass; in this combination, a type of safety glass results which optimally unites structural properties with features providing active and passive safety.

This combination of increased mechanical strength, resistance to temperature differences and residual structural strength makes it the ideal product for:

- dividing walls
- overhead glazing
- balustrades
- point-supported glazing
- load-bearing glass elements such as steps.

The processing options for heat-strengthened glass, e.g. for

- edges
- holes
- notches
- edge and corner cut-outs

correspond to those for thermally toughened safety

As with thermally toughened safety glass, such processing must be done before the heat-strengthening process. See Section 5.7.1.

INTERPANE has been granted a "General authorisation by building inspection authorities" for heat-strengthened glass. This covers both monolithic heat-strengthened glass and laminated glass made of heat-strengthened glass for glazing applications with linear or point supports.

Thus, authorisation is no longer needed for individual cases.

This means that our clients no longer have to bear the costs for the extensive bending, fragmentation and building component tests.

A copy of the authorisation can be requested from INTERPANE Hildesheim.

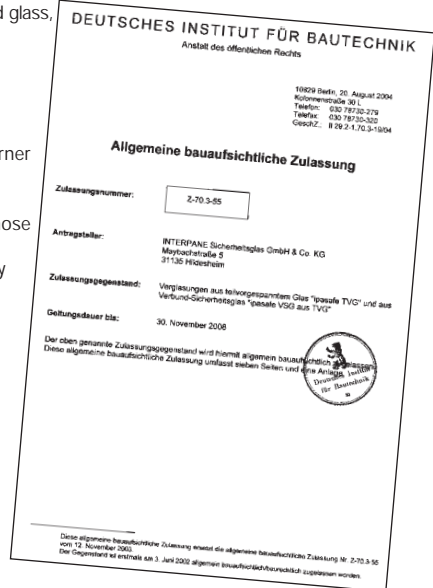

## 5 Description of INTERPANE Products



### Properties

	float glass	heat-strengthened glass	thermally toughened safety glass
mechanical (tensile bending) strength $\sigma_B$	45 N/mm <sup>2</sup>	70 N/mm <sup>2</sup>	120 N/mm <sup>2</sup>
permissible $\sigma_{zul}$ depending on the application	12/18 N/mm <sup>2</sup> *	29 N/mm <sup>2</sup> **	50 N/mm <sup>2</sup>
permissible temperature difference $\Delta\theta$ over the pane area	40 K	100 K	200 K
can be cut	yes	no	no
fragmentation structure	radial cracks, large pieces	radial cracks, large pieces	network of cracks, small blunt pieces
spontaneous breakage possible	no	no	yes

\* 12 N/mm<sup>2</sup> for overhead glazing, 18 N/mm<sup>2</sup> for vertical glazing

\*\* calculated value corresponding to the general authorisation

### Application areas

<b>vertical areas</b>	float glass	heat-strengthened glass	thermally toughened safety glass
without safety requirements	●		
with safety requirements			●
higher mechanical loads		●	●
higher thermal loads		●	●
residual structural stability when supported on all sides		●	
<b>overhead glazing</b>	float glass	heat-strengthened glass	thermally toughened safety glass
outer pane	●	●	●
monolithic inner pane	forbidden	forbidden	forbidden
inner pane of laminated safety glass (residual structural strength) consisting of 2 x	●	●	forbidden
<b>balustrades</b>	float glass	heat-strengthened glass	thermally toughened safety glass
monolithic			●
laminated safety glass consisting of 2 x	●	●	●
(with residual structural strength)		●	
laminated safety glass consisting of 2 x			

INTERPANE uses the following definitions:

- residual structural stability  
The ability for a glass pane to remain standing for a limited duration, under certain installation conditions, if no further load is applied after the glass element has been damaged.
- residual structural strength  
A further-reaching property than residual self-support, meaning that, for a limited duration after damage, the glass element continues to completely fill the frame aperture and to bear limited loads.

## 5 Description of INTERPANE Products



Requirements on the quality of heat-strengthened glass

### a) Scope

These quality criteria apply to flat, heat-strengthened glass, which has been produced by the horizontal production process, for use in buildings and constructions.

The following basic products are used to produce heat-strengthened glass:

- Glass: – float glass  
EN 572, Part 2  
– patterned glass (cast glass) EN 572, Part 5

The glass can be

- colourless or coloured
- transparent, translucent, opaque or opalescent
- coated or enamelled
- surface-treated, e.g. sand-blasted or etched.

### b) Tolerances

Nominal thicknesses and tolerances for basic products according to EN 1863, Part 1

nominal thickness in mm	tolerances in mm	
	float glass	patterned glass
–	± 0.2	± 0.5
4		
5		
6		
8	± 0.3	± 0.8
10		± 1.0
12		–

Tolerances on the width (B) and length (H) derived from EN 1863, Part 1

Length H or width B of the glass edge	absolute tolerance nominal thickness ≤ 12 mm	absolute tolerance nominal thickness > 12 mm
up to 500 mm	± 1.0 mm	± 2.0 mm
up to 1000 mm	± 1.5 mm	± 2.0 mm
up to 2000 mm	± 2.0 mm	± 2.5 mm
up to 3000 mm	± 2.5 mm	± 3.0 mm
up to 3500 mm	± 3.0 mm	± 4.0 mm
more than 3500 mm	± 3.5 mm	± 5.0 mm

Heat-strengthened glass for coating

The quality criteria concerning tolerances, flatness, etc. may be stricter for heat-strengthened glass products which are to be coated. INTERPANE should be consulted prior to ordering.

## 5 Description of INTERPANE Products

### Flatness

The deviation from flatness depends on the thickness, the dimensions and the ratio of edge lengths of a pane. The deformation is known as bow. Two types of bow are distinguished: overall or general bow, and local bow.

#### Overall or general bow ( $t_G$ )

The glass pane is placed at room temperature in a vertical position and supported on its longer side by two load-bearing blocks at the quarter points.

The deformation is measured as the maximum distance  $h_1$  from a straight metal ruler or a stretched wire to the concave surface of the glass (see figure). It is measured along the edges of the glass and along the diagonals.

In all cases, the value for overall bow is expressed as the ratio of the deformation  $h_1$  to the measured length of the edge of the glass (B or H as applicable) or the diagonal.

$$t_G = \frac{h_1}{B \text{ oder } H} \left[ \frac{\text{mm}}{\text{m}} \right]$$

#### Local bow ( $t_L$ )

Local bow is measured over a limited length of 300 mm by using a straight ruler, or a stretched wire (see figure). It is expressed as the ratio of the distance  $h_2$  to a length of 300 mm:

$$t_L = \frac{h_2}{300} \left[ \frac{\text{mm}}{\text{mm}} \right]$$

For patterned glass, local bow is determined by using a straight ruler resting on the high points of the pattern and measuring to a high point of the pattern.

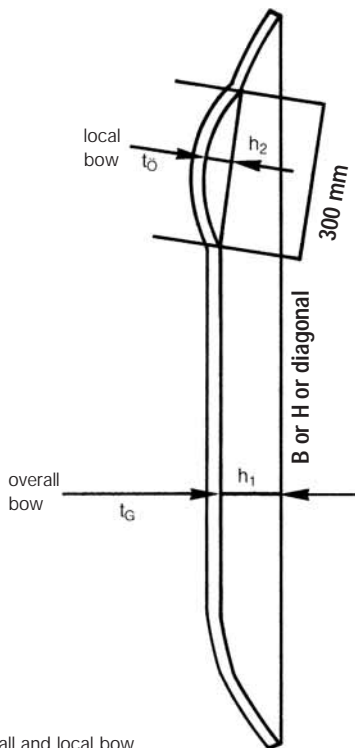

Overall and local bow

Maximum values for overall and local bow			
type of glass	glass thickness [mm]	maximum values for	
		overall bow [mm/m]	local bow [mm/300 mm]
heat-strengthened glass made of float glass	3 – 12	3*	0.3
heat-strengthened glass made of patterned glass	4 – 10	4	0.5

\* For square and nearly square formats with a ratio of side lengths between 1:1 and 1:1.3, the deviation from flatness is inevitably greater than for narrower rectangular formats. Particularly for glass thicknesses  $\leq 6$  mm, INTERPANE should be consulted before ordering.

## 5 Description of INTERPANE Products



### c) Deviations in pattern and colour

It is fundamentally impossible to guarantee that the structure of several adjacent panes of patterned glass will be symmetric.

The direction of a pattern should be specified in the order. If this specification is missing, the glass pane will be produced with the direction of the pattern parallel to the pane height.

For reasons relating to the production technology, shifts in the design and slight colour differences are possible with patterned glass and coloured glass.

### d) Tests

Within the framework of the factory production control and third-party surveillance, the production of ipasafe thermally toughened glass is regularly tested in accordance with the relevant standards.

Fragmentation structure according to EN 1863, Part 1.

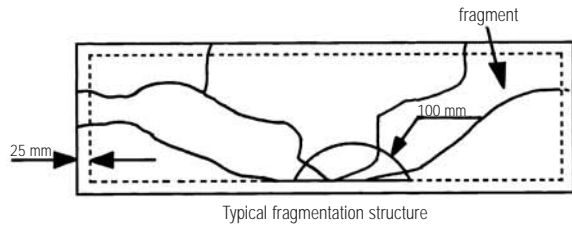

Mechanical strength (bending tensile strength) according to EN 1863, Part 1 / EN 1288, Part 3

type of glass		nominal thickness [mm]	mechanical strength (bending tensile strength**) [N/mm <sup>2</sup> ]
heat-strengthened glass made of	float glass	3 – 12	70
	ceramic-coated glass	3 – 12	45 *)
	patterned float glass	4 – 10	55

\*) ceramic-coated surface in tension

\*\*) The mechanical strength value (bending tensile strength) is defined as the minimum quasi-static bending load for which a lower confidence limit of 95 % leads to a 5 % probability of breakage.

## 5 Description of INTERPANE Products



### e) Visual assessment of quality

The testing principles and relevant tables for visual assessment are defined in the "Guideline to assess the visual quality of architectural glazing", published in Section 7.7.5.

The permissibility of deviations which are observed during these tests is decided according to these testing principles and tables.

### f) Physical characteristics

#### Optical features

As the glass lies on rollers in the furnace during the heat-strengthening process, slight changes in the surface can occur occasionally. These so-called "roller waves" are caused by physical processes and cannot always be avoided. In the individual case, they can cause a slight distortion of the reflected image.

The thermal toughening process can also cause chemical and mechanical changes in the surface structure such as small spots ("roller pick-up") and roller impressions.

#### Anisotropy

Anisotropic iridescent effects can be observed on heat-strengthened glass. A detailed explanation of these effects can be found in Section 4.12.

### Thermal durability

The mechanical properties of heat-strengthened glass are unchanged for application temperatures up to 250 °C. Heat-strengthened glass can resist both sudden temperature changes and temperature differences across the pane surface of up to 100 K.

### Wettability of the glass surface by moisture

The wettability of the glass surface can vary due to the effect of traces from rollers, fingerprints, labels, paper grain, vacuum suction cups, slurries or lubricants.

If the glass surfaces are moistened by condensation, rain or cleaning water, the differing wettability can become evident. These effects are typical characteristics and do not provide a reason for reclamation.

### g) Marking

Every pane of ipasafe heat-strengthened glass is marked at least with "EN 1863" and the name or logo of the manufacturer. According to this standard, the marking must be indelible.

### Delivery programme for heat-strengthened glass

#### max. dimensions in cm for ipasafe heat-strengthened glass

type of glass	colour	glass thickness / dimensions							
		4 mm	5 mm	6 mm	8 mm	10 mm	12 mm	15 mm	19 mm
float glass	clear	150x250	200x300	260x450	260x450	260x450	260/450	-	-
float glass	blue	-	-	200x300	200x300	200x300	-	-	-
float glass	bronze	150x250	200x300	260x450	260x450	260x450	260/450	-	-
float glass	grey	150x250	200x300	260x450	260x450	260x450	260/450	-	-
float glass	green	150x250	200x300	260x450	260x450	260x450	-	-	-
translucent glass	translucent	150x250	200x300	260x450	260x450	260x450	260/450	-	-
satin-finished glass	translucent	150x250	200x300	260x450	260x450	260x450	200x300	-	-
SR Mastercarre	translucent	100x200	-	150x210	200x300	-	-	-	-

Heat-strengthened glass gains safety properties if it is laminated to form laminated safety glass.

Dimensions up to 600 cm are available on request.

Minimum dimensions: 20 cm x 30 cm for rectangular ipasafe heat-strengthened glass  
 Minimum diameter: 30 cm  
 Maximum ratio of side lengths: 1 : 10  
 Maximum mass: 350 kg per glazing unit

- For square and nearly square formats with a ratio of side lengths between 1:1 and 1:1.3, the deviation from flatness is inevitably greater than for narrower rectangular formats. Particularly for glass thicknesses  $\leq 6$  mm, INTERPANE should be consulted before ordering.

## 5 Description of INTERPANE Products

### 5.7.3 Laminated safety glass

Product description  
of laminated safety glass  
according to EN 14 449

In the production of laminated safety glass, two or more glass panes lying on top of each other are firmly joined together by one or more highly elastic interlayers of polyvinyl butyral (PVB).

During the production process, a roller press or similar equipment is used to prepare a preliminary laminate. This is then transformed to a permanent laminate, consisting of the glass panes and interlayers, by application of heat and pressure in an autoclave.

The customary "glass-clear" appearance in transmission can be slightly affected, depending on the number and thickness of interlayers.

Laminated safety glass has the property that in the case of breakage, the glass fragments adhere to the interlayer. This means that practically no sharp-edged glass splinters become detached. This minimises the risk of injury considerably.

In addition, the tough elastic interlayer hinders the penetration of the entire glazing element, so that active safety is raised significantly (resistance to manual or bullet attack, depending on the construction).

Compared to thermally toughened safety glass, laminated safety glass is distinguished by a decisive advantage: In the case of breakage, a pane of thermally toughened safety glass crumbles into small pieces. Usually the pane collapses completely. As a result, thermally toughened safety glass then does not offer any further protection against burglary or injury.

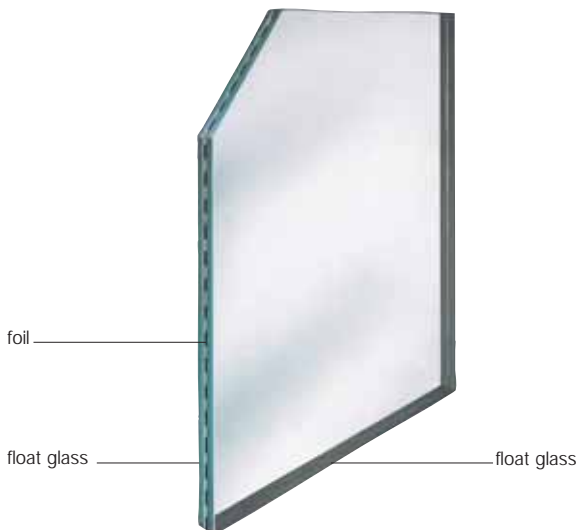

Cross-section through laminated safety glass

By contrast, after laminated safety glass has been broken, it still acts to seal the frame aperture. The residual structural stability and strength guarantee that even after laminated safety glass has been damaged, it still protects life and property for a certain period of time.

Depending on the construction, combinations of several panes and PVB interlayers of different thicknesses can provide additional protection against manual and bullet attack.

As well as laminated safety glass panes with PVB interlayers, laminated glass without safety properties is available.

As part of the initial type testing, laminated safety glass must meet the following specifications according to EN 14 449:

- A) High-temperature test according to EN ISO 12 543, Part 4 (boiling test at 100 °C for 2 hours)
- B) High-humidity test with condensation according to EN ISO 12543, Part 4 (condensation test at 50 °C and 100 % relative humidity for two weeks)
- C) Radiation test according to EN ISO 12 543, Part 4 (2000 h exposure to 900 W/m<sup>2</sup> radiation with a quasi-solar spectrum)
- D) Pendulum test according to EN 12 600 (twin-tyre impactor, 50 kg, drop height of 450 mm)

## 5 Description of INTERPANE Products



As part of the factory production control process, samples of the continually produced laminated safety glass are subjected to the following tests:

- boiling test and condensation test (see p. 157 A and B)
- sphere drop test (mechanical strength, 4 m drop, 1 kg sphere)
- pummel test (test of adhesion between glass and interlayer)

Modern production technology allows lamination not only of several float glass panes, but also thermally toughened safety glass, heat-strengthened glass, certain types of patterned glass, polished wired glass and glass with solar-control or low-e (plus E) coatings.

Laminated glass combines high mass per pane area with low bending stiffness due to the elastic interlayers which join the panes of glass to each other. This improves the rated sound reduction index compared to that of monolithic panes of the same thickness.

As a further option, special sound-insulating interlayers can be used to combine the safety features of laminated safety glass with increased sound insulation.

Application areas for laminated safety glass

The ideal application areas for laminated safety glass result from its properties of retaining glass splinters and residual self-support if breakage occurs:

### ● Public buildings

Most of the German state building authorities recommend laminated safety glass for the entire entrance area.

In some states, this is obligatory for schools and kindergartens.

### ● Sport buildings

In addition to the application in the building entrances, laminated safety glass is also recommended in the areas where sport and games are played due to its mechanical resistance to ball impact up to certain limits.

Similarly, installation of laminated safety glass around indoor pools is a sensible safety precaution.

### ● Industrial and commercial sectors

Laminated safety glass is applied here especially to protect against burglary. To increase security and for quick detection of a break-in, the glass can also be equipped with a conductive circuit to trigger an alarm.

### ● Residential sector

Apart from protection against burglary, laminated safety glass is primarily installed here to protect life and limb, e.g. as transparent door components or in glazing units extending over the height of a complete storey.

### ● Balustrades

Glass is used in banisters and balustrades to reduce the risk of falling off stairs and balconies. Proof of safety in the case of breakage of laminated safety glass is to be provided by pendulum tests according to EN 12 600 (see also Section 7.7.3).

### ● Overhead glazing

The inner pane of overhead glazing must be made of laminated safety glass consisting of float or heat-strengthened glass for safety reasons (see also Section 7.7.1).

Further processing of laminated safety glass

It is clear that panes of laminated safety glass can be further processed by coating and production of thermally insulating glazing (iplus neutral E) or solar-control glazing (ipaso).

Test report for ipasafe on resistance to ball impact  
 Laminated safety glass 8 mm  
 max. dimensions: 2100 mm x 3600 mm  
 The validity of the test report is regularly renewed with  
 unchanged content.



**MPA STUTTGART**  
 Otto-Graf-Institut  
 Materialprüfungsanstalt • Universitäts Stuttgart

Materialprüfungsanstalt Otto-Graf-Institut, Universitäts Stuttgart • FG 5.150 • Sportstätten, Sportstättenbau • 70503 Stuttgart  
 (Übergeordnete Prüfleistungsfähigkeit)

Telefon: 0711/666-2729, ad: 3379 • Fax: 0711/666-2726 • E-mail: Inca.mef@ipb.uni-stuttgart.de

**Prüfzeugnis**

**INTERPANE Sicherheitsglas GmbH & Co. KG**  
 31135 Hildesheim  
 Prüfung der Ballwurfsicherheit  
 nach DIN 18 032 Teil 3 Ausgabe April 1997

Datum des Prüfzeugnisses : 28.09.2005  
 Auftrag : 55150/901 0322/Sc/Kf  
 Textseiten : 4  
 Beilagen : 1

Das gemäß Tabelle 5 und 6a Beilagen sind mit unseren Dienstleistungen verbunden. Die Verarbeitung und Verflechtung des Belegtes ist  
 gekürzt. Weiterhin ist die Verwendung zur Verflechtung für nur in unserer amtlichen Genehmigung und nur innerhalb eines Zeitraumes  
 von 2 Jahren nach der Auslastung zulässig. Gleichstand und Erlaubnisse in Stuttgart

Seite 1 von 5 Seiten

vom 28.09.2005

Prüfzeugnis 55150/901 0322



**INTERPANE Sicherheitsglas GmbH & Co. KG**  
 Maybachstr. 5

31135 Hildesheim

Unsere Zeichen : 55150/901 0322/Sc/Kf  
 Betreff : Prüfung der Ballwurfsicherheit  
 nach DIN 18 032 Teil 3

Wir wurden von der Fa. INTERPANE Sicherheitsglas (Hildesheim) beauftragt, eine Sport-  
 hallenverglasung auf Ballwurfsicherheit entsprechend der DIN 18032 Teil 3 „Sporthallen,  
 Hallen für Turnen und Spiele und Mehrzwecknutzung; Prüfung der Ballwurfsicherheit. Aus-  
 gabe April 1997 zu prüfen.

Dazu brachte die Firma das zu prüfende Element am 01.09.2005 in unserem Ballschütz-  
 prüfstand an.

**1. Beschreibung des Einbauelements**

Bei dem untersuchten Einbauelement handelte es sich um die Wandverglasung

„ipasafe VSG 82 mm“

Das Verbund Sicherheitsglas hatte die Abmessungen 3600 mm x 2100 mm x 8 mm und  
 hatte folgenden Aufbau:

- 4 mm Float Glas
- 1 x 0,38 mm PVB-Folie
- 4 mm Float Glas

Seite 2 von 5 Seiten



Test report for ipasafe on resistance to ball impact  
 Laminated safety glass 8 mm  
 max. dimensions: 2100 mm x 3600 mm  
 The validity of the test report is regularly renewed with  
 unchanged content.



Dieser Prüfnachweis ist gültig bis zum 28.09.2007.

Eine Wiedernachprüfung ist zu diesem Zeitpunkt nur dann nicht erforderlich, wenn der Antragsteller nachweist und sich vom Prüfinstitut bestätigen läßt, daß das geprüfte Einbauelement in den wesentlichen Teilen unverändert produziert und eingebaut wird.

  
 Schmid  
 Sachbearbeiter



  
 Dipl.-Ing. Knauer  
 Referatsleiter

Zur Prüfung war die Sporthallenverglasung in einen Holzrahmen eingesetzt.  
 Zwischen Holzrahmen und Scheibe war rundum ein Schaumstoffklebeband angelegt.

**2. Durchführung der Prüfung**

Die Prüfung erfolgte nach DIN 18 032 Teil 3 „Sporthallen, Hallen für Turnen und Spiele und Mehrzwecknutzung, Prüfung der Ballwurfsicherheit“ Ausgabe April 1997.

Die Prüfung erfolgte bei Raumtemperatur im Labor.

**3. Prüfungsergebnis**

Ball	Auftreffwinkel in Grad	Anzahl der Schüsse	Veränderungen am Einbauelement
Handball	90	30	
Handball	45	12	
Handball	45	12	keine
Hockeyball	90	4	
Hockeyball	45	4	
Hockeyball	45	4	

Das geprüfte Einbauelement überstand die Beanspruchung ohne Schäden. Es erwies sich somit als ballwurfsicher nach DIN 18 032 Teil 3.

## 5 Description of INTERPANE Products

Processing options for laminated safety glass

### a) Edge finishing

The production technology for laminated safety glass made of thermally untreated float glass does not require any form of edge-finishing. For laminated safety glass made of thermally toughened or heat-strengthened products, the edge-finishing possibilities correspond to those of thermally toughened glass (see Sections 5.7.1 and 5.7.2).

If the client requests it, the following forms of edge-finishing as described in EN ISO 12 543, Part 5 can be offered:

- **Arrissed**  
An arrissed edge corresponds to a cut edge which has been bevelled to some extent by a grinding tool.
- **Ground**  
The glass pane is machined to the required dimensions by grinding the edges. The ground edges can have broken borders (corresponding to an arrissed edge). Blank spots and conchoidal fractures are permissible.
- **Smooth ground**  
The whole area of the edge is ground. The borders are bevelled by grinding. Smooth ground edges appear matt. Blank spots and conchoidal fractures are not permissible.
- **Polished**  
The polished edge is a ground edge which has been further finished by polishing. Polishing traces are permissible to a certain extent.

- **Bevel edge**  
All types of ipasafe laminated safety glass can be produced with a bevel edge which forms an angle  $\alpha$  to the glass surface, where  $45^\circ \leq \alpha < 90^\circ$ .

The edges can be "smooth ground" or "polished".

The maximum glass thickness is 50 mm.

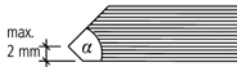

The edges are finished either manually or with machines, depending on the length of the edge and the shape of the pane.

For panes which must be at least partially manually edge-finished, we recommend manual edge finishing around the entire perimeter for optical reasons. Technical clarification is necessary for the specific case.

INTERPANE should be consulted before laminated safety glazing units weighing more than 500 kg are ordered.

### b) Cant corners

The production technology requires that custom-shaped panes with acute angles of  $< 30^\circ$  be cut back.

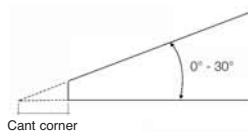

## 5 Description of INTERPANE Products



### c) Edge options

#### ● Recessed edge

Laminated safety glass can also be produced with a stepped edge profile. The recessed edge usually runs parallel to one or more edges. After consultation, special options such as corner sections are possible.

ipasafe laminated safety glass with a recessed edge

single step (side view)

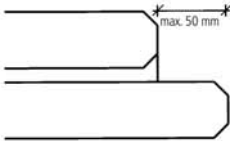

double step (side view)

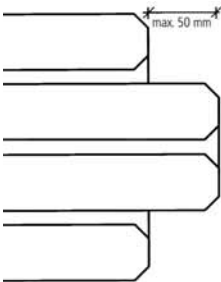

- The panes are processed individually to produce recessed edges.
- See p. 164 for displacement tolerances.
- maximum dimensions: 200 cm x 300 cm, other dimensions on request
- minimum production dimensions: 25 cm x 45 cm
- maximum ratio of side lengths: 1:10
- option also available in combination with thermally toughened safety glass or heat-strengthened glass

#### ● Edge trimming of interlayer

For laminated safety glass made of thermally toughened glass, the edges must be finished before lamination. If the edge is polished or smoothly ground, the PVB interlayer is trimmed back to the glass edge for optical reasons.

### d) Cut-outs, holes audio grills

Accurate drawings which specify all technical details must be supplied for these processing steps.

The thickness of the laminated safety glass must be at least 8 mm.

## 5 Description of INTERPANE Products



Requirements on the quality of laminated safety glass

### a) Scope

These quality criteria apply to flat, laminated safety glass for use in buildings and constructions.

The following basic products are used to produce laminated safety glass:

Glass:

- float glass EN 572, Part 2
- drawn sheet glass EN 572, Part 4
- patterned glass (cast glass) EN 572, Part 5
- thermally toughened safety glass EN 12 150, Part 1
- heat-strengthened glass EN 1863, Part 1
- other types of flat glass

The glass can be

- colourless or coloured
- transparent, translucent, opaque or opalescent
- coated or enamelled (ceramic)
- surface-treated, e.g. sand-blasted or etched.

Polyvinyl butyral (PVB) interlayer:

The interlayers can be

- colourless or coloured,
- transparent, translucent or opaque.

### b) Tolerances

Nominal thicknesses and tolerances according to EN 572, Parts 2, 4 and 5

The nominal thickness of laminated safety glass is the sum of the individual thicknesses of the basic products used for its production.

- nominal thickness of PVB interlayer 0.38 mm and 0.76 mm.

### Nominal thicknesses and tolerances according to paragraph a)

nominal thickness [mm]	tolerances in mm		
	drawn sheet glass	patterned glass	float glass
3	± 0.2	± 0.5	± 0.2
4			
5			
6	± 0.3	± 0.8	± 0.3
8			
10	± 0.5	± 1.0	± 0.5
12	± 0.6	-	
15	-	-	± 1.0
19	-	-	± 1.0

The permissible thickness tolerance of laminated safety glass is the sum of the permissible tolerances of the basic products used for its production. The tolerance for the interlayer thickness is not taken into account.

It should be noted that depending on the type of basic product used, it may be necessary to use additional interlayer films due to the requirements of the production technology.

Tolerances on the width (B) and length (H) for laminated safety glass made of thermally untreated glass derived from EN 12 543, Part 5

edge finishing		Tolerances (t) in mm on the width (B) and length (H)					
		cut and arised		ground, smoothly ground or polished and bevelled			
element thickness [mm]		≤ 8	> 8		≤ 26	≤ 40	> 40
			each individual glass pane in laminate < 10	with an individual glass pane in laminate ≥ 10			
nominal dimensions (cut sizes) [cm]	up to 100	± 1.0	± 2.0	+ 2.5 - 2.0	+ 1.0 - 2.0	+ 1.0 - 3.0	+ 1.0 - 3.0
	up to 200	± 1.5	+ 3.0 - 2.0	± 3.5	+ 1.0 - 3.0		
	more than 200	+ 2.5 - 2.0	+ 3.5 - 3.0	± 4.0			
standard dimensions		± 3.0					

E 73

## 5 Description of INTERPANE Products



Tolerances on the width (B) and length (H) for laminated safety glass made of thermally toughened or heat-strengthened glass derived from EN 12 543, Part 5

edge finishing		Tolerances (t) in mm on the width (B) and length (H)		
		arrissed		ground, smoothly ground or polished
element thickness [mm]		≤ 8	> 8	general
nominal dimensions [cm]	up to 100	± 2.0	± 2.0	± 2.0
	up to 200	+ 3.0 - 2.0	+ 3.0 - 2.0	+ 3.0 - 2.0
	more than 200	+ 3.0	+ 3.5	+ 4.0

### Displacement tolerance

Due to the production technology, the individual glass panes can become misaligned.

- laminated safety glass of thermally untreated glass  
Misalignment tolerances occur only for laminates with cut or arrissed edges and lie within the tolerances for width and length (see Table on p. 163).
- laminated safety glass of thermally toughened or heat-strengthened glass  
Misalignment tolerances occur for all types of edge finishing for these products and are specified in the following table. The width B and length H must be considered separately.

### Maximum permissible displacement

nominal dimension (B or H)	maximum permissible displacement
B, H ≤ 100 cm	2.0 mm
B, H ≤ 200 cm	3.0 mm
B, H > 200 cm	4.0 mm

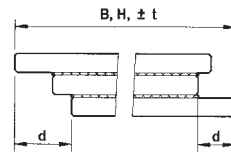

## 5 Description of INTERPANE Products



Tolerances on cut-outs and audio grills

These tolerances depend on the individual technical specifications. Please clarify before placing an order.

Tolerances on holes

The tolerances on the hole diameter are:

for  $\leq 24$  mm element thickness:  
 $\pm 2.0$  mm  
for  $> 24$  mm element thickness:  
 $\pm 2.5$  mm

The tolerances on the hole positions are:

for thermally untreated glass:  
 $\pm 1.5$  mm  
for thermally toughened or heat-strengthened glass:  $\pm 2.5$  mm

These tolerances due to the production technology must be taken into account in addition to the tolerances which are required due to aspects of the construction and installation.

c) Laminated safety glass for coating

The quality criteria may be stricter for laminated safety glass products which are to be coated. INTERPANE should be consulted prior to ordering.

d) Deviations in colour of the laminate

Please note that as the laminate thickness increases, the intrinsic colour of the laminate may become evident as a green/yellow tint.

e) Tests

Within the framework of the factory production control and third-party surveillance, the production of ipasafe laminated glass is regularly tested in accordance with the relevant standards.

- mechanical strength (bending tensile strength) according to EN 1288, Part 3
- sphere drop test according to EN 14 449
- boiling test according to EN 12543, Part 4
- pendulum test according to EN 12 600

The requirements on laminated safety glass for security glazing to protect persons and objects are defined in the following standards:

- EN 356, EN 1063, EN 13 541
- VdS Guideline 2163 (VdS - German association of damage-prevention experts)
- accident prevention regulation (Unfallsverhütungsvorschrift - UVV) for banks

f) Visual assessment of quality

The testing principles and relevant tables for visual assessment of monolithic laminated safety glass panes are defined in the "Guideline to assess the visual quality of architectural glazing". This defines the testing principles and permissible tolerances (see Section 7.7.5.).

g) Marking

Cut-size panes of ipasafe laminated safety glass are marked. Multiple markings are possible. The marking must be legible and permanent.

## 5 Description of INTERPANE Products



### Delivery programme for cut-size, monolithic, ipasafe laminated safety glass

Cut-size laminates of two panes	
type	maximum dimensions [cm]
5/2	120 x 216
6/2	225 x 321
8/2	260 x 420
10/2	260 x 420
12/2	260 x 420
14/2	260 x 420
16/2	260 x 420
18/2	260 x 420
20/2	260 / 420
22/2	260 / 420
24/2	260 / 420
30/2	260 / 420
38/2	260 / 420

Cut-size laminates of more than two panes	
type	maximum dimensions [cm]
9/3	225 x 321
12/3	260 x 420
15/3	260 x 420
18/3	260 x 420
16/4	260 x 420
20/4	260 / 420
24/4	260 / 420

Cut-size, two-pane laminated safety glass of thermally toughened or heat-strengthened ipasafe glass		
type	maximum dimensions [cm]	type of glass
6/2	100 x 150	only TVG*
8/2	100 x 200	ESG** or TVG*
10/2	120 x 300	ESG** or TVG*
12/2	260 x 420	ESG** or TVG*
16/2	260 x 420	ESG** or TVG*
20/2	260 / 420	ESG** or TVG*
24/2	260 / 420	ESG** or TVG*
30/2	260 / 420	only ESG**

\* TVG – heat-strengthened glass  
 \*\* ESG – thermally toughened glass

Cut-size combinations with special glass			
type of glass	colour	glass thickness [mm]	max. dimensions [cm]
Ornament 504	translucent	4	150 x 210
Ornament 597	translucent	4	150 x 210
SR Chinchilla	translucent	4	150 x 210
SR Chinchilla	bronze	4	150 x 210
SR Chinchilla	translucent	6	150 x 210
SR Listral 200	translucent	6	150 x 210
SR Mastercarre	translucent	4	150 x 210
Stopsol super silber clear		6	150 x 210
satin-finished glass	translucent	4	150 x 210
satin-finished glass	translucent	5	150 x 210
satin-finished glass	translucent	6	150 x 210
satin-finished glass	translucent	8	150 x 210

- Dimensions up to 600 cm are available on request.
- Minimum dimensions: 25 cm x 45 cm for rectangular ipasafe laminated safety glass
- Minimum diameter: 45 cm
- Maximum diameter: 180 cm
- Maximum ratio of side lengths: 1:10
- Maximum mass: 500 kg per glazing unit

F73

## 5 Description of INTERPANE Products



### 5.7.4 ipasafe security glazing

Over the last few decades, the number of burglaries affecting private dwellings has multiplied. The police has thus intensified its advice to take precautionary measures. These are intended to effectively thwart a burglary or to cause so much delay that the burglars give up because their break-in attempts would attract too much attention.

At the same time, as the standard of living has risen, so has the demand by individuals to protect their property and valuables, particularly if the houses are in exposed or endangered locations.

Laminated safety glass is the transparent building material which is best suited to provide

adequate protection against attack.

In addition to the resistance which laminated safety glass offers to attack, additional deterrence and thus more security is given by the combination of alarm circuits in the glazing with warning systems.

## 5 Description of INTERPANE Products



Product description of ipasafe security glazing

ipasafe security glazing products are laminated safety glass products which comply with EN 14 449 and are thus subject to the obligatory mechanisms of initial type testing and ongoing factory production control. Depending on the type of resistance offered, they are divided into the following groups:

- resistance to manual attack Level 3
- bullet resistance Level 1
- resistance to explosion Level 1

For the Level 1 products, not only factory production control but also third-party surveillance by a notified body is obligatory.

The attack face is defined during the initial type testing of ipasafe security glazing. This determines the orientation for installation.

All ipasafe security insulating glass units are generally designed such that the attack face corresponds to the outer pane of the units. Thus, the attack face is defined as "position 1".

If, for specific buildings such as prisons, the other side should be the attack face, or if a non-standard outer pane such as alarm-wired thermally toughened glass is required, this must already be taken into account during the planning phase. Furthermore, the manufacturer must be notified when the order is placed and the dimensioning must

comply with structural building regulations. Often, the maximum pane areas specified in the delivery programmes are reduced as a result.

For the reasons presented above, it is not permissible to arbitrarily change the installation orientation, e.g. by turning the glazing around. Accordingly, ipasafe security glazing is clearly labelled in this respect.

The relevant standards concerning security glazing are EN 356 for resistance to manual attack, EN1063 for bullet resistance and EN 13 541 for resistance to explosion.

## 5 Description of INTERPANE Products



- a) Glazing providing resistance to manual attack - thrown objects

The standards classify glazing according to their resistance against thrown objects. The protection offered increases with the

number of the resistance class. The testing procedure is based on the assumption of heavy thrown objects, which are simulated by a drop test with a metal sphere weighing app. 4110 g and having a diameter of 10 cm. The sphere is dropped several times onto each

sample (110 cm x 90 cm) from a specified height. The test has been passed if none of the spheres penetrate the sample. The different testing requirements and the resulting resistance categories of the relevant standard are presented in the following table.

Resistance to manual attack - categories according to drop test		
EN 356		
category of resistance	drop height [mm]	number of spheres* dropped
P1A	1500	3
P2A	3000	3
P3A	6000	3
P4A	9000	3
P5A	9000	3 x 3

\* sphere mass: 4.1 kg

INTERPANE holds testing certificates for ipasafe P1A to P5A.

## 5 Description of INTERPANE Products



### Delivery programme for standard ipasafe security glazing products offering resistance to manual attack - categories according to drop test

#### Technical data: ipasafe P1A - P5A according to EN 356

type	product resistance category according to EN 356	configuration (outer/space/ inner for IGU's) mm	thickness mm	mass kg/m <sup>2</sup>	max. dimensions cm	max. area m <sup>2</sup>	max. ratio of side lengths -	application areas
ipasafe	P1A	7 / 10 / 4	21	26	141 x 240	3.40	1:6	houses and apartments in built-up areas
		7 / 10 / 6	23	31	225 x 321	7.22	1:10	
		monolithic	9	21	260 x 420	10.92	1:10	
ipasafe	P2A	9 / 10 / 4	23	31	141 x 240	3.40	1:6	
		9 / 10 / 6	25	36	250 / 400	8.00	1:10	
		monolithic	9	21	260 x 420	10.92	1:10	
ipasafe	P3A	9 / 10 / 4	23	31	141 x 240	3.40	1:6	isolated private buildings
		9 / 10 / 6	25	36	250 / 400	8.00	1:10	
		monolithic	9,5	22	260 x 420	10.92	1:10	
ipasafe	P4A	9,5 / 10 / 4	23	32	141 x 240	3.40	1:6	houses with valuable contents and remote holiday flats
		9,5 / 10 / 6	25	37	250 / 400	8.00	1:10	
		monolithic	10,5	22	260 x 420	10.92	1:10	
ipasafe	P5A	10,5 / 10 / 4	24	32	141 x 240	3.40	1:6	
		10,5 / 10 / 6	26	37	250 / 400	8.00	1:10	

- All types listed above can be combined with iplus E low-e coated glass as the indoor pane.  
U<sub>g</sub> values: 16 mm space = 1.1 W/m<sup>2</sup>K (argon gas fill) EN 673  
10 mm space = 1.0 W/m<sup>2</sup>K (krypton gas fill) EN 673  
The specified rated values refer to the testing conditions and the application scope of the referenced standard.
- If the ipasafe pane is intended to be the indoor pane, it can be combined with an ipasol solar-control pane as the outer pane.
- Combinations with patterned glass or alarm-wired thermally toughened glass are also possible.
- Please note that as the laminate thickness increases, the intrinsic colour of the laminate may become evident as a green/yellow tint. This effect can be reduced by the use of low-iron glass.
- The customer ordering our products is responsible for ensuring that the glass thickness is dimensioned correctly according to the applicable technical regulations.
- Minimum dimensions: 25 cm x 45 cm for rectangular ipasafe laminated safety glass
- Minimum diameter: 45 cm
- Maximum diameter: 180 cm
- Maximum mass: 500 kg per glazing unit

## 5 Description of INTERPANE Products



### Delivery programme for special ipasafe security glazing products providing resistance to manual attack - categories according to drop test

Technical data: <b>ipasafe special types - monolithic glazing</b>								
product		config-uration	thickness	mass	max. dimensions	max. area	max. ratio of side lengths	application areas
type	resistance category according to EN 356							
			mm	kg/m <sup>2</sup>	cm	m <sup>2</sup>	–	
ipasafe 8/2 heat-strengthened glass	<b>P3A</b>	monolithic	9.5	22	100 x 200	2.00	1:10	room partitions
ipasafe 10/2 heat-strengthened glass	<b>P3A</b>	monolithic	11.5	27	120 x 300	3.60	1:10	
ipasafe 12/2 heat-strengthened glass	<b>P3A</b>	monolithic	13.5	32	260 x 420	10.92	1:10	
ipasafe 10/2 thermally toughened safety glass	<b>P4A</b>	monolithic	11.5	27	120 x 300	3.60	1:10	
ipasafe 8/2-alarm	<b>P4A</b>	monolithic	9.5	22	100 x 200	2.00	1:10	display window glazing, villas in prime locations

- Please note that as the laminate thickness increases, the intrinsic colour of the laminate may become evident as a green/yellow tint. This effect can be reduced by the use of low-iron glass.
- The customer ordering our products is responsible for ensuring that the glass thickness is dimensioned correctly according to the applicable technical regulations.
- Minimum dimensions: 25 cm x 45 cm for rectangular ipasafe laminated safety glass
- Minimum diameter: 45 cm
- Maximum diameter: 180 cm
- Maximum mass: 500 kg per glazing unit

E-7A

## 5 Description of INTERPANE Products



771

- b) Glazing providing resistance to manual attack - hand-held implements

The standards classify glazing into three categories according to their resistance against attack with manually held implements. The protection offered increases with the number of the resistance class. A mechanically swung axe weighing 2 kg is used for the test. The number of axe strikes is determined which is required to produce a 400 mm x 400 mm square opening in the sample (110 x 90 cm).

The different testing requirements and the resulting resistance categories of the relevant standard are presented in the following table.

Resistance to manual attack - categories according to axe test	
EN 356	
category of resistance	number of axe strikes
P6B	30 to 50
P7B	51 to 70
P8B	more than 70

The number and type of axe strikes which the sample survives determines the category of resistance to manual attack with a hand-held implement.

The tested glazing type is allocated the lowest resistance category determined for three samples.

INTERPANE holds testing certificates for ipasafe P6B to P8B.

### Delivery programme for standard ipasafe security glazing products providing resistance to manual attack - categories according to axe test

product		configuration	thickness	mass	max. dimensions	max. area	max.ratio of side lengths	addi-tional function	application examples
type for IGU's)	resistance category according to EN 356	(outer/ space/inner)	mm	kg/m <sup>2</sup>	cm	m <sup>2</sup>			
			ipasafe	<b>P6B</b>	monolithic	18	39		
	18/10/6	34	54		250 / 400	8.00	1:6		
ipasafe	<b>P7B</b>	monolithic	24	54	260 / 420	9.26	1:10	BR3-S	galleries, museums, antique shops, department stores, psychiatric institutions
		24/10/6	40	69	250 / 400	7.25	1:6		
ipasafe	<b>P8B</b>	monolithic	31	67	260 / 420	7.46	1:10	BR4-S	jeweller's shops, fur shops, prisons
		31/10/6	47	82	250 / 400	6.10	1:6		

- All types listed above can be combined with iplus E low-e coated glass as the indoor pane.  
 $U_g$  value: 16 mm space = 1.1 W/m<sup>2</sup>K (argon gas fill) EN 673  
 10 mm space = 1.0 W/m<sup>2</sup>K (krypton gas fill) EN 673  
 The specified rated values refer to the testing conditions and the application scope of the referenced standard.
- If the ipasafe pane is intended to be the indoor pane, it can be combined with an ipasol solar-control pane as the outer pane.
- Combinations with patterned glass or alarm-wired thermally toughened glass are also possible.
- Please note that as the laminate thickness increases, the intrinsic colour of the laminate may become evident as a green/yellow tint. This effect can be reduced by the use of low-iron glass.
- The customer ordering our products is responsible for ensuring that the glass thickness is dimensioned correctly according to the applicable technical regulations.
- Minimum dimensions: 25 cm x 45 cm for rectangular ipasafe laminated safety glass
- Minimum diameter: 45 cm
- Maximum diameter: 180 cm
- Maximum mass: 500 kg per glazing unit

## 5 Description of INTERPANE Products



Anti-burglar glazing with VdS approval

To determine the insurance premiums for insured property, the German association of experts for damage prevention, VdS Schadenverhütung GmbH, tests the resistance of anti-burglar glazing (einbruchhemmend - EH) to the different types of manual attack. The approved products are published in a list.

These glazing types are divided into five resistance categories:

- EH01
- EH02
- EH1
- EH2
- EH3

Which resistance category is required for a certain individual object depends on the prevailing circumstances. The insurance company should be consulted early in the planning process.

## 5 Description of INTERPANE Products



### Delivery programme for ipasafe security glazing products tested according to VdS criteria (VdS - German association of damage prevention experts)

Technical Data: ipasafe EH								
product		configuration (outer/space/ inner for IGU's)	thick- ness	mass	max. dimen- sions	max. area	max ratio of side lengths	application examples (see also Section 3.7 - Windows and Safety)
type	resistance category according to VdS		mm	kg/m <sup>2</sup>	cm	m <sup>2</sup>	-	
ipasafe	EH01	monolithic	9.5	22	260 x 420	10.92	1 : 10	houses with valuable contents and remote holiday flats
		9.5/10/4	23	32	141 x 240	3.40	1 : 6	
		9.5/10/6	25	37	250 / 400	8.00	1 : 10	
ipasafe 10/2 thermally toughened safety glass	EH01	monolithic	11.5	27	120 x 300	3.60	1 : 10	room partitions
ipasafe	EH02	monolithic	11	23	260 x 420	10.92	1 : 10	villas, high-risk objects
		11/10/4	25	33	141 x 240	3.40	1 : 6	
		11/10/6	27	38	250 / 400	8.00	1 : 10	
ipasafe	EH1	monolithic	18	39	260 x 420	10.92	1 : 10	photo and video shops, pharmacies, sections of department stores, computer centres
		18/10/6	34	54	250 / 400	8.00	1 : 6	
ipasafe	EH2	monolithic	25	51	260 / 420	9.80	1 : 10	galleries, museums, antique shops, depart- ment stores, psychiatric institutions
		25/10/6	41	66	250 / 400	7.58	1 : 6	
ipasafe	EH3	monolithic	36	78	260 / 420	6.41	1 : 10	jeweller's shops, fur shops, prisons
		36/10/6	52	93	250 / 400	5.38	1 : 6	

- All ipasafe EH types listed above can be combined with iplus E low-e coated glass as the indoor pane.  
U<sub>g</sub> values: 16 mm space = 1.1 W/m<sup>2</sup>K (argon gas fill) EN 673  
10 mm space = 1.0 W/m<sup>2</sup>K (krypton gas fill) EN 673  
The specified rated values refer to the testing conditions and the application scope of the referenced standard.
- If the ipasafe pane is intended to be the indoor pane, it can be combined with an ipasol solar-control pane as the outer pane.
- Combinations with patterned glass or alarm-wired thermally toughened glass are also possible.
- Please note that as the laminate thickness increases, the intrinsic colour of the laminate may become evident as a green/yellow tint. This effect can be reduced by the use of low-iron glass.
- The customer ordering our products is responsible for ensuring that the glass thickness is dimensioned correctly according to the applicable technical regulations.
- The ipasafe EH types are tested and approved by VdS (German association of damage prevention experts).
- Minimum dimensions: 25 cm x 45 cm for rectangular ipasafe laminated safety glass
- Minimum diameter: 45 cm
- Maximum diameter: 180 cm
- Maximum mass: 500 kg per glazing unit

E-7A

## 5 Description of INTERPANE Products



### c) Bullet-resistant security glazing

ipasafe bullet-resistant security glazing from INTERPANE provides the greatest degree of protection for life and limb. The test prescribes three shots at the test sample at a testing temperature of 18 °C (± 5 °C), whereby the shots are to be positioned at a fixed distance from each other. The resistance categories differ according to the calibre of the

ammunition used. In addition, non-splintering (NS) and splintering (S) categories are differentiated.

Non-splintering ipasafe units are installed where a person could be positioned directly behind the pane during an attack.

INTERPANE holds testing certificates for all types of ipasafe bullet-resistant security glazing. Advice should be obtained if the testing

conditions differ significantly from the application circumstances.

As all types of bullet-resistant security glazing consist of multi-pane, asymmetrically configured laminated safety glass, these products automatically provide better protection against burglary.

The resistance categories are listed in the following table.

Categories of bullet-resistant glazing according to EN 1063						
calibre	ammunition		bullet resistance class		test range [m]	bullet velocity [m/s]
	*) type	mass g	splintering	non-splintering		
.22 LR	L/RN	2.6±0.10	BR1-S	BR1-NS	10	360 ± 10
9 mm Luger	FJ/RN/SC	8.0±0.10	BR2-S	BR2-NS	5	400 ± 10
.357 Magn.	FJ/CB/SC	10.25±0.10	BR3-S	BR3-NS	5	430 ± 10
.44 Rem Magn.	FJ/FN/SC	15.55±0.10	BR4-S	BR4-NS	5	440 ± 10
5.56 x 45	FJ/PB/SCP 1	4.0±0.10	BR5-S	BR5-NS	10	950 ± 10
7.62x51	FJ/PB/SC	9.45±0.10	BR6-S	BR6-NS	10	830 ± 10
7.62x51	FJ/PB/HC1	9.75±0.10	BR7-S	BR7-NS	10	820 ± 10
cal. 12/70	Brenneke	31.0±0.50	SG1-S**)	SG1-NS**)	10	420 ± 20
cal. 12/70	Brenneke	31.0±0.50	SG2-S	SG2-NS	10	420 ± 20

\*) L: lead  
 CB: coned bullet  
 FJ: full metal jacket  
 FN: flat nose  
 HC1: steel hard core  
 PB: pointed bullet  
 RN: round nose  
 SC: soft core (lead)  
 SCP1: soft core (lead) and steel penetrator

\*\*\*) The test consists of a single shot.

## 5 Description of INTERPANE Products



### Delivery programme for monolithic ipasafe bullet-resistant security glazing products

#### Technical Data: ipasafe BR1-BR7, SG1, SG2

product		thickness	mass	max. dimensions	max. area	max. ratio of side lengths
type	resistance category according to EN 1063					
		mm	kg/m <sup>2</sup>	cm	m <sup>2</sup>	
ipasafe	<b>BR1-S</b>	10,5	22	260 x 420	10,92	1:10
ipasafe	<b>BR1-NS</b>	18	42	260 x 420	10,92	1:10
ipasafe	<b>BR2-S</b>	19	43	260 x 420	10,92	1:10
ipasafe	<b>BR2-NS</b>	28	67	260 / 420	7,46	1:10
ipasafe	<b>BR3-S</b>	23	53	260 / 420	9,43	1:10
ipasafe	<b>BR3-NS</b>	34	82	260 / 420	6,09	1:10
ipasafe	<b>BR4-S</b>	29	65	260 / 420	7,69	1:10
ipasafe	<b>BR4-NS</b>	51	123	260 / 420	4,07	1:10
ipasafe	<b>BR5-S</b>	45	105	260 / 420	4,76	1:10
ipasafe	<b>BR5-NS</b>	63	151	260 / 420	3,31	1:10
ipasafe	<b>BR6-S</b>	47	111	260 / 420	4,50	1:10
ipasafe	<b>BR6-NS</b>	70	169	260 / 420	2,96	1:10
ipasafe	<b>BR7-S</b>	78	186	260 / 420	2,67	1:10
ipasafe	<b>BR7-NS</b>	78	186	260 / 420	2,67	1:10
ipasafe	<b>SG1-S</b>	34	82	260 / 420	6,09	1:10
ipasafe	<b>SG1-NS</b>	63	151	260 / 420	3,31	1:10
ipasafe	<b>SG2-S</b>	45	105	260 / 420	4,76	1:10
ipasafe	<b>SG2-NS</b>	70	169	260 / 420	2,96	1:10

- Please note that as the laminate thickness increases, the intrinsic colour of the laminate may become evident as a green/yellow tint. This effect can be reduced by the use of low-iron glass.
- The customer ordering our products is responsible for ensuring that the glass thickness is dimensioned correctly according to the applicable technical regulations.
- Minimum dimensions: 25 cm x 45 cm for rectangular ipasafe laminated safety glass
- Minimum diameter: 45 cm
- Maximum diameter: 180 cm
- Maximum mass: 500 kg per glazing unit

## 5 Description of INTERPANE Products



### Delivery programme for ipasafe bullet-resistant security glazing products as insulating glass units

#### Technical data: ipasafe BR1-BR7, SG1, SG2

product		configuration (outer/space/ inner for IGU's)	thickness	mass	max. dimensions	max. area	max. ratio of side lengths
type	resistance category according to						
	EN 1063	mm	mm	kg/m <sup>2</sup>	cm	m <sup>2</sup>	-
ipasafe	<b>BR1-S</b>	10.5/10/6	26	37	250 / 400	8.00	1:6
ipasafe	<b>BR1-NS</b>	11/10/9	30	47	260 / 420	10.60	1:6
ipasafe	<b>BR2-S</b>	14.5/10/9	33	53	260 / 420	9.40	1:6
ipasafe	<b>BR2-NS</b>	23.5/10/9	42	77	260 / 420	6.50	1:6
ipasafe	<b>BR3-S</b>	13/10/10.5	33	53	260 / 420	9.40	1:6
ipasafe	<b>BR3-NS</b>	28.5/10/11	49	93	260 / 420	5.30	1:6
ipasafe	<b>BR4-S</b>	11/10/20	41	70	260 / 420	7.10	1:6
ipasafe	<b>BR4-NS</b>	34.5/10/13	57	113	260 / 420	4.40	1:6
ipasafe	<b>BR5-S</b>	17/10/22	49	90	260 / 420	5.50	1:6
ipasafe	<b>BR5-NS</b>	35/10/11.5	56	110	260 / 420	4.50	1:6
ipasafe	<b>BR6-S</b>	17/10/26	53	100	260 / 420	5.00	1:6
ipasafe	<b>BR6-NS</b>	48/10/11.5	69	141	260 / 420	3.50	1:6
ipasafe	<b>BR7-S</b>	34.5/10/34.5	79	165	260 / 420	3.00	1:6
ipasafe	<b>SG1-S</b>	17/10/22	49	90	260 / 420	5.50	1:6
ipasafe	<b>SG1-NS</b>	35/10/11.5	56	110	260 / 420	4.50	1:6
ipasafe	<b>SG2-S</b>	35/10/11.5	56	110	260 / 420	4.50	1:6
ipasafe	<b>SG2-NS</b>	48/10/11.5	69	141	260 / 420	3.50	1:6

- All ipasafe EH types listed above can be combined with iplus E low-e coated glass as the indoor pane.  
 $U_g$  values: 10 mm space = 1.4 W/m<sup>2</sup>K (argon gas fill) EN 673  
 10 mm space = 1.0 W/m<sup>2</sup>K (krypton gas fill) EN 673  
 The specified rated values refer to the testing conditions and the application scope of the referenced standard.
- Combinations with ipasol solar-control glazing, patterned glass or alarm-wired thermally toughened glass are possible under certain conditions. Consultation during the planning phase is necessary.
- Please note that as the laminate thickness increases, the intrinsic colour of the laminate may become evident as a green/yellow tint. This effect can be reduced by the use of low-iron glass.
- The customer ordering our products is responsible for ensuring that the glass thickness is dimensioned correctly according to the applicable technical regulations.
- Minimum dimensions: 25 cm x 45 cm for rectangular ipasafe laminated safety glass
- Minimum diameter: 45 cm
- Maximum diameter: 180 cm
- Maximum mass: 500 kg per glazing unit

## 5 Description of INTERPANE Products



d) Glazing providing resistance to explosion pressure according to EN 13 541

This standard specifies requirements and testing procedures for the classification of explosion-resistant security glazing for use in buildings. The main requirement on explosion-resistant security glazing is to protect humans against blast waves.

The procedure is intended to test only those types of explosion-resistant security glazing which have already been allocated a certain resistance category according to EN 356. Thus, the ER types always also possess further security properties concerning manual attack by thrown objects or hand-held implements, depending on the category.

The samples are tested under well-defined conditions; the test determines the maximum positive pressure of a reflected shock wave which a glazing type withstands for a longer period of time.

The classification is only valid for the tested glass sizes of about 1 m<sup>2</sup>.

Classification of explosion-resistant security glazing according to EN 13 541

classification code	characteristics of the plane shock wave minimum values of the		
	positive maximum overpressure of the reflected blast wave (Pr) [kPa]	positive specific impulse (i+) [kPa x ms]	duration of the positive pressure phase (t+) [ms]
ER 1	$50 \leq Pr < 100$	$370 \leq i+ < 900$	$\geq 20$
ER 2	$100 \leq Pr < 150$	$900 \leq i+ < 1500$	$\geq 20$
ER 3	$150 \leq Pr < 200$	$1500 \leq i+ < 2200$	$\geq 20$
ER 4	$200 \leq Pr < 250$	$2200 \leq i+ < 3200$	$\geq 20$

E 7 A

### 5.7.5 ipasafe security glazing conforming to bank requirements

To protect endangered zones of their premises, such as counters and cash desks, banks have defined their own guidelines for the installation of bullet-resistant laminated security glazing.

ipasafe bank glass optimally meets these security specifications.

Bank glazing is available as monolithic panes for indoor applications.

According to the German accident prevention regulation (Unfallverhütungsvorschrift - UVV) for banks, the only type of glazing which is permitted in newly equipped premises is

BR3-S / P7B.

In addition, the ipasafe Bank 14/2 product, which is classified as P3A, can be used as a barrier to prevent burglars climbing over the counter.

### Delivery programme for ipasafe bank glazing products

Technical data: <b>ipasafe bank glass - monolithic glazing</b>						
(combination tested according to the criteria of the accident-prevention regulation for banks (UWV))						
product		thickness	mass	max. dimensions	max. area	max. ratio of side lengths
type	resistance category according to					
	EN 1063/356	mm	kg/m <sup>2</sup>	cm	m <sup>2</sup>	-
ipasafe bank	BR3-S / P7B	28	64	260 / 420	7.80	1 : 10
ipasafe bank	climbing barrier 14 / 2*	13.5	32	260 x 420	10.92	1 : 10

\* Additional function: resistance category P3A (resistant to manual attack - thrown objects)

- Please note that as the laminate thickness increases, the intrinsic colour of the laminate may become evident as a green/yellow tint. This effect can be reduced by the use of low-iron glass.

## 5 Description of INTERPANE Products



### 5.7.6 Overview of the delivery programme for ipasafe security glazing

Comments on the following tables

- The maximum mass per glazing unit is 500 kg.
- The specified rated values refer to the testing conditions and the application scope of the referenced standard or the testing conditions of the VdS (German association of damage prevention experts).
- The customer ordering our products is responsible for ensuring that the glass thickness is dimensioned correctly according to the applicable technical regulations.
- Early consultation with INTERPANE's applications experts is necessary if larger glass thicknesses or gas-filled spaces are intended.

## 5 Description of INTERPANE Products



Table I: ipasafe delivery programme - monolithic security glazing

product		thickness	approx. mass	additional properties	alarm wiring possible	max. dimensions	max. area	max. ratio of side lengths
type	resistance category	mm	kg/m <sup>2</sup>			cm	m <sup>2</sup>	
		ipasafe	P1A	7	16	–	–	225 x 321
ipasafe	P2A	9	21	–	–	260 x 420	10.92	1:10
ipasafe	P3A	9	21	–	–	260 x 420	10.92	1:10
ipasafe	P4A	9.5	22	–	–	260 x 420	10.92	1:10
ipasafe	P5A	10.5	22	–	–	260 x 420	10.92	1:10
ipasafe 8/2 heat-strengthened glass	P3A	9.5	22	–	–	100 x 200	2.00	1:10
ipasafe 10/2 heat-strengthened glass	P3A	11.5	27	–	–	120 x 300	3.60	1:10
ipasafe 12/2 heat-strengthened glass	P3A	13.5	32	–	–	260 x 420	10.92	1:10
ipasafe 10/2 thermally toughened safety glass	P4A	11.5	27	–	–	120 x 300	3.60	1:10
ipasafe 8/2-alarm	P4A	9.5	22	–	yes	100 x 200	2.00	1:10
ipasafe	P6B	18	39	BR2-S/EH1	–	260 x 420	10.92	1:10
ipasafe	P7B	24	54	BR3-S	–	260 / 420	9.26	1:10
ipasafe	P8B	31	67	BR4-S	–	260 / 420	7.46	1:10
ipasafe	EH01	9.5	22	–	–	260 x 420	10.92	1:10
ipasafe 10/2 thermally toughened safety glass	EH01	11.5	27	–	–	120 x 300	3.60	1:10
ipasafe	EH02	11	23	–	–	260 x 420	10.92	1:10
ipasafe	EH1	18	39	–	–	260 x 420	10.92	1:10
ipasafe	EH2	25	51	–	–	260 / 420	9.80	1:10
ipasafe	EH3	36	78	–	–	260 / 420	6.41	1:10
ipasafe	BR1-S	10.5	22	–	–	260 x 420	10.92	1:10
ipasafe	BR1-NS	18	42	–	–	260 x 420	10.92	1:10
ipasafe	BR2-S	19	43	–	–	260 x 420	10.92	1:10
ipasafe	BR2-NS	28	67	–	–	260 / 420	7.46	1:10
ipasafe	BR3-S	23	53	–	–	260 / 420	9.43	1:10
ipasafe	BR3-NS	34	82	–	–	260 / 420	6.09	1:10
ipasafe	BR4-S	29	65	–	–	260 / 420	7.69	1:10
ipasafe	BR4-NS	51	123	–	–	260 / 420	4.07	1:10
ipasafe	BR5-S	45	105	–	–	260 / 420	4.76	1:10
ipasafe	BR5-NS	63	151	–	–	260 / 420	3.31	1:10
ipasafe	BR6-S	47	111	–	–	260 / 420	4.50	1:10
ipasafe	BR6-NS	70	169	–	–	260 / 420	2.96	1:10
ipasafe	BR7-S	78	186	–	–	260 / 420	2.67	1:10
ipasafe	BR7-NS	78	186	–	–	260 / 420	2.67	1:10
ipasafe	SG1-S	34	82	–	–	260 / 420	6.09	1:10
ipasafe	SG1-NS	63	151	–	–	260 / 420	3.31	1:10
ipasafe	SG2-S	45	105	–	–	260 / 420	4.76	1:10
ipasafe	SG2-NS	70	169	–	–	260 / 420	2.96	1:10
ipasafe bank	BR3-S/P7B	28	64	–	–	260 / 420	7.80	1:10
ipasafe bank	climbing barrier 14/2	13.5	32	P3A	–	260 x 420	10.92	1:10

## 5 Description of INTERPANE Products



Table II: ipasafe delivery programme - security insulating glass units

product			element thickness	approx. mass	additional properties	alarm wiring possible	max. dimensions	max. area	max. ratio of side lengths
type	resistance category	configuration	mm	kg/m <sup>2</sup>			cm	m <sup>2</sup>	
ipasafe	P1A	7/10/4	21	26	–	yes	141 x 240	3.40	1:6
ipasafe	P1A	7/10/6	23	31	–	yes	225 x 321	7.22	1:10
ipasafe	P2A	9/10/4	23	31	–	yes	141 x 240	3.40	1:6
ipasafe	P2A	9/10/6	25	36	–	yes	250 / 400	8.00	1:10
ipasafe	P3A	9/10/4	23	31	–	yes	141 x 240	3.40	1:6
ipasafe	P3A	9/10/6	25	36	–	yes	250 / 400	8.00	1:10
ipasafe	P4A	9.5/10/4	23	32	–	yes	141 x 240	3.40	1:6
ipasafe	P4A	9.5/10/6	25	37	–	yes	250 / 400	8.00	1:10
ipasafe	P5A	10.5/10/4	24	32	–	yes	141 x 240	3.40	1:6
ipasafe	P5A	10.5/10/6	26	37	–	yes	250 / 400	8.00	1:10
ipasafe	P6B	18/10/6	34	54	BR2-S/EH1	yes	250 / 400	8.00	1:6
ipasafe	P7B	24/10/6	40	69	BR3-S	yes	250 / 400	7.25	1:6
ipasafe	P8B	31/10/6	47	82	BR4-S	yes	250 / 400	6.10	1:6
ipasafe									
ipasafe	EH01	9.5/10/4	23	32	–	yes	141 x 240	3.40	1:6
ipasafe	EH01	9.5/10/6	25	37	–	yes	250 / 400	8.00	1:10
ipasafe	EH02	11/10/4	25	33	–	yes	141 x 240	3.40	1:6
ipasafe	EH02	11/10/6	27	38	–	yes	250 / 400	8.00	1:10
ipasafe	EH1	18/10/6	34	54	–	yes	250 / 400	8.00	1:6
ipasafe	EH2	25/10/6	41	66	–	yes	250 / 400	7.58	1:6
ipasafe	EH3	36/10/6	52	93	–	yes	250 / 400	5.38	1:6
ipasafe									
ipasafe	BR1-S	10.5/10/6	26	37	–	–	250 / 400	8.00	1:6
ipasafe	BR1-NS	11/10/9	30	47	–	–	260 / 420	10.60	1:6
ipasafe	BR2-S	14.5/10/9	33	53	–	–	260 / 420	9.40	1:6
ipasafe	BR2-NS	23.5/10/9	42	77	–	–	260 / 420	6.50	1:6
ipasafe	BR3-S	13/10/10.5	33	53	–	–	260 / 420	9.40	1:6
ipasafe	BR3-NS	28.5/10/11	49	93	–	–	260 / 420	5.30	1:6
ipasafe	BR4-S	11/10/20	41	70	–	–	260 / 420	7.10	1:6
ipasafe	BR4-NS	34.5/10/13	57	113	–	–	260 / 420	4.40	1:6
ipasafe	BR5-S	17/10/22	49	90	–	–	260 / 420	5.50	1:6
ipasafe	BR5-NS	35/10/11.5	56	110	–	–	260 / 420	4.50	1:6
ipasafe	BR6-S	17/10/26	53	100	–	–	260 / 420	5.00	1:6
ipasafe	BR6-NS	48/10/11.5	69	141	–	–	260 / 420	3.50	1:6
ipasafe	BR7-S	34.5/10/34.5	79	165	–	–	260 / 420	3.00	1:6
ipasafe									
ipasafe	SG1-S	17/10/22	49	90	–	–	260 / 420	5.50	1:6
ipasafe	SG1-NS	35/10/11.5	56	110	–	–	260 / 420	4.50	1:6
ipasafe	SG2-S	35/10/11.5	56	110	–	–	260 / 420	4.50	1:6
ipasafe	SG2-NS	48/10/11.5	69	141	–	–	260 / 420	3.50	1:6

## 5 Description of INTERPANE Products



### 5.7.7 ipasafe alarm

ipasafe alarm is a pane of thermally toughened safety glass which is additionally equipped with an alarm loop designed for connection to a burglar alarm system. As a semi-finished product, it can be further processed into insulating glass units or monolithic laminated safety glass.

#### Operating principle

The alarm is triggered by an electrically conductive alarm loop which is enamelled onto the surface of the thermally toughened safety glass pane. As a thermally toughened safety glass pane always fractures over the entire area if it is damaged, the alarm loop will be interrupted and triggers an alarm signal from the connected alarm system. The thermally toughened alarm-wired pane must be positioned toward the direction of attack (attack face).

#### Electric properties of the alarm loop

The maximal permissible current is 0.5 A. The resistance of the alarm loop is  $6 \Omega \pm 3 \Omega$ .

This low resistance value means that a large number of ipasafe alarm-wired panes can be connected to a main cable. This is advantageous for windows divided into small pane areas, e.g. with glazing bars.

The resistance between the alarm loop and the sabotage connection (middle wire) is greater than 20 M $\Omega$ . This ensures compatibility with conventional commercially available alarm systems.

#### Connection cable

An approximately 30 cm long, four-wire, flexible, single-coloured, round cable is supplied for connection to the burglar alarm system. Each wire cross-section is 0.14 mm<sup>2</sup>. The connection cable is equipped with a moisture-protected flat plug by the manufacturer.

A 5 m or 10 m extension cable, also equipped with a moisture-protected socket, is available as an accessory.

The advantage of this moisture-protected plug-and-socket connection is that neither a soldered connection nor a heat-shrunk insulator is needed at the building site. This makes quick and safe installation feasible.

If the glazing must be replaced, an electrician is not needed; the plug-and-socket connection can be made by the glazier.

When security systems with alarm-wired glass are used, compatibility between the glazing, frame and other safety components should already be ensured during the planning phase.

The corresponding guidelines of the VdS should be observed (VdS - German association of damage prevention experts).

Maximum dimensions for ipasafe alarm-wired panes of thermally toughened glass

glass thickness	width x length in cm
4 mm	150 x 250
5 mm	200 x 300
6 mm	260 x 450
8 mm	260 x 450
10 mm	260 x 450
12 mm	260 x 450
15 mm	260 / 450

If the ipasafe alarm-wired glazing is constructed of laminated safety glass, the corresponding restrictions on dimensions must be taken into account (see Section 5.7.3).

For an insulating glass unit, the permissible dimensions can be found in the section on the corresponding product category.

As with all thermally toughened panes, subsequent machining is not possible. Thus, the exact dimensions must be specified on the order.

#### Position of the alarm loop

When ipasafe alarm is ordered, the position of the alarm loop must be specified.

Four options are available for ipasafe alarm-wired insulating glazing:

VdS Schadenverhütung GmbH recommends that the alarm loop always be positioned in the upper part of the glazing. (VdS - German association of damage prevention experts)

Upper left edge  
(Rand oben links)  
= ROL



Upper right edge  
(Rand oben rechts)  
= ROR



Lower left edge  
(Rand unten links)  
= RUL

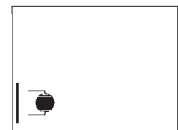

Lower right edge  
(Rand unten rechts)  
= RUR

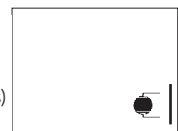

(views from indoors)

For ipasafe alarm-wired glazing with laminated glass, the alarm loop may be installed only in the upper left or upper right positions.

## 5 Description of INTERPANE Products



Variants of the ipasafe alarm loop

The alarm loop is visible in the standard version delivered. The form is related to the INTERPANE trademark.

This makes the building security system also visible externally and additionally indicates that burglary attempts will have consequences. ipasafe alarm-wired thermally toughened safety glass thus acts as a deterrent.

For application areas where a visible alarm loop should be avoided for optical reasons (e.g. ipasol solar-control glazing), ipasafe alarm is available in a variant with an inconspicuous alarm circuit applied at the edge of the glass. When the pane is installed in a conventional window frame, this alarm circuit is covered by the glass rebate and is thus practically invisible.

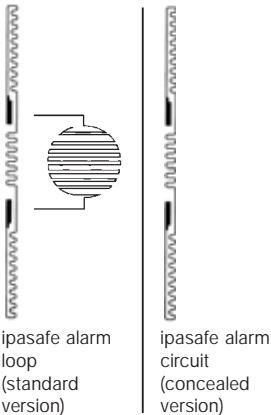

ipasafe alarm-wired insulating glass units

All ipasafe safety insulating glass units with security glazing and all glazing types tested by the VdS

(German association of damage prevention experts) can be equipped with an additional alarm loop. Other combinations can be delivered on demand. This also applies for conventional insulating glass configurations and coated insulating glass units.

ipasafe alarm-wired insulating glazing has been tested by the VdS and approved with the authorisation number G 103139.

Alarm-wired thermally toughened safety glass combined in an insulating glass unit with laminated safety glass provides the greatest protection possible against burglary. The first attack triggers the alarm, and the ipasafe laminated pane then hinders entry, so that counter-measures can be taken.

The "Glazing Guidelines" according to Section 6.4.13 must be ob-

served in the installation of ipasafe alarm-wired insulating glass units.

ipasafe alarm-wired glazing with laminated safety glass  
The monolithic ipasafe alarm-wired glazing element with laminated safety glass (VSG) has been approved by the VdS with the authorisation number G 192005.

ipasafe alarm-wired glazing with laminated safety glass can also be delivered as a monolithic security glazing element with resistance to manual attack with thrown objects or hand-held implements. Laminated ipasafe alarm-wired glazing cannot be provided in the concealed-loop variant.

The "Glazing Guidelines" according to Section 6.4.13 must be observed in the installation of laminated ipasafe alarm-wired glazing in the monolithic form.

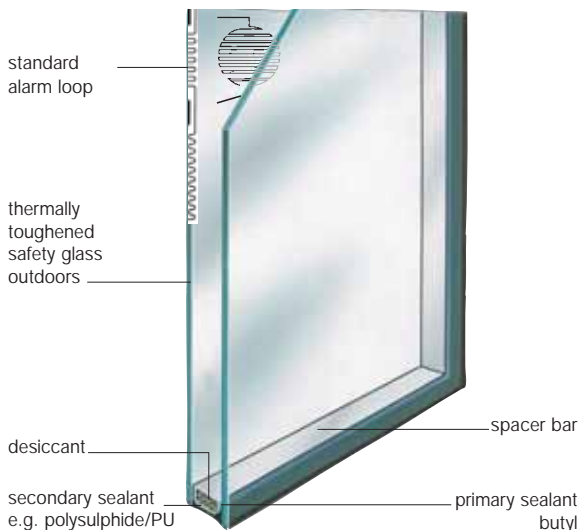

Cross-section through an ipasafe alarm-wired insulating glass unit

## 5 Description of INTERPANE Products



### 5.8 Practical applications of safety glass

Modern architecture is an architecture of light and transparency. Today's discerning planners and building owners demand glass constructions as a substitute for non-transparent materials.

These demands on the one hand and the diversity of our safety glass range on the other hand make a comprehensive

spectrum of practical glass applications feasible.

From the "simple" interior door up to complex glass constructions which completely replace formerly required building materials - the sophisticated material, glass, is a visible expression of contemporary architecture.

- 5.8.1 ipador all-glass doors
- 5.8.2 ipador all-glass door systems
- 5.8.3 ipador horizontal sliding walls
- 5.8.4 ipius HT anti-reflective glazing
- 5.8.5 ipasafe construction glass
- 5.8.6 Processing for glass support systems
- 5.8.7 ipatec point-supported canopy systems and overhead glazing
- 5.8.8 ipasafe S flooring glass
- 5.8.9 Glazing for lifts / elevators

## 5 Description of INTERPANE Products



### 5.8.1 ipador all-glass doors

#### Model: ipador S

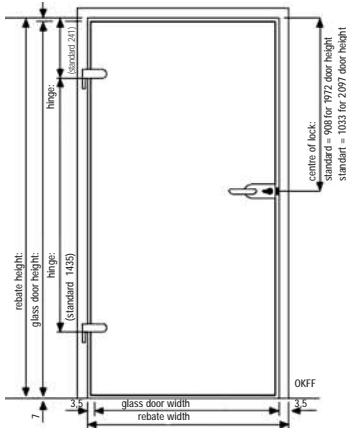

#### Model: ipador J

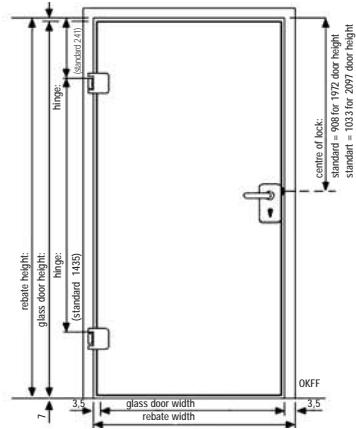

F01

The ipador product range includes a comprehensive and sophisticated programme of all-glass doors for interior living and working areas.

ipador all-glass doors let light into rooms, define structures without separating, and create a feeling of spaciousness.

With a wide selection of up-to-date glass designs and modern, functional, metal fittings, the glass doors can be chosen to fit in harmoniously with the interior decoration scheme. For particularly individual interior design, we recommend the ipador jewel range (see page 190).

The doors are delivered in common standard dimensions (Model S, Model J) or are custom-made in dimensions and designs specified by the client. Model S differs from Model J in the type and construction of the fittings, depending on the requirements of the door frame.

Standard dimensions of doors for installation in rebated frames:

Standard height 1 = 1972 mm				
raw building construction dimensions	mm	750 x 2000	875 x 2000	1000 x 2000
frame rebate dimensions	mm	716 x 1983	841 x 1983	966 x 1983
glass dimensions	mm	709 x 1972	834 x 1972	959 x 1972
glass dimensions for door with rail	mm	709 x 1942	834 x 1942	959 x 1942
Standard height 1 = 2097 mm				
raw building construction dimensions	mm	750 x 2125	875 x 2125	1000 x 2125
frame rebate dimensions	mm	716 x 2108	841 x 2108	966 x 2108
glass dimensions	mm	709 x 2097	834 x 2097	959 x 2097
glass dimensions for door with rail	mm	709 x 2067	834 x 2067	959 x 2067

During planning, the direction in which the door opens should always be clearly defined. The patterned side is always the side on which the hinge is mounted, i.e. the patterned side faces the direction of opening.

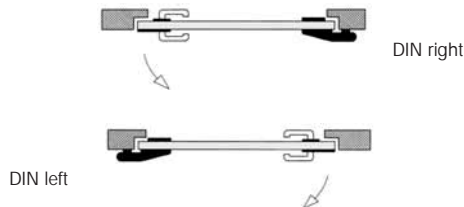

Illustration of the DIN directions of rebated frames with hinges.

## 5 Description of INTERPANE Products



Types of glass deliverable for ipador all-glass doors						
Type of glass	model	ipador S and ipador J			ipador Variant	
		dimensions and glass thickness in mm				
	standard height 1:	709 x 1972	834 x 1972	959 x 1972	< 1000 x 2100	< 1200 x 2300
	standard height 2:	709 x 2097	834 x 2097	959 x 2097		
colour		8 mm	8 mm	8 mm	8 mm	10 mm
float glass	clear	X	X	X	X	X
float glass	blue	X	X	X	X	X
float glass	bronze	X	X	X	X	X
float glass	grey	X	X	X	X	X
float glass	green	X	X	X	X	X
satin-finished glass	translucent	X	X	X	X	X
SR Barock	translucent	X	X	X	X	-
SR Chinchilla	translucent	X	X	X	X	-
SR Listral 200	translucent	X	X	X	X	X
SR Madera 176	translucent	X	X	X	X	-
SR Mastercarre	translucent	X	X	X	X	X
SR Masterligne	translucent	X	X	X	X	-
SR Masterpoint	translucent	X	X	X	X	-
SR Silvit 178	translucent	X	X	X	X	X
SR Chinchilla	bronze	X	X	X	X	-
SR Silvit 178	bronze	X	X	X	X	-

Fittings in different forms and colours that harmonise with the interior decoration can be delivered as complete sets.



Lock-handle combination



Door hinge



Lock-handle combination



Door hinge

## 5 Description of INTERPANE Products



ipador juwel all-glass doors with style

This door range sets accents. The transparency of the safety glass in combination with attractive designs makes every room appear spacious and gives it an individual highlight.

Colour, shape, light and glass enter an aesthetic union with ipador juwel. Glass doors not only create architectural space but also identify the interior as a creative room element.

ipador juwel - screen-printed ceramic on glass

These ipador juwel all-glass doors are coated with high-quality enamel layers in a screen-printing process. The ceramic layer, which is fired onto the surface during the thermal toughening process, does not fade and is durable and scratch-resistant.



ipador juwel - refined matt surfaces on glass

A fine sand jet creates a matt surface and conjures filigree forms, structures and patterns onto the surface of the ipador juwel all-glass door.



ipador juwel - fluted bevel on glass

Classic or modern - ipador juwel doors with a fine fluted bevel design for that special touch in a home.



ipador juwel - appliqué on glass

Whether it is just an additional accent on an ipador juwel all-glass door or as a general design element: appliqué elements of glass, metal, wood or stone give a visual accent and underline your personal style.



On request, doors can be designed in many different ways in accordance with individual plans. We are happy to advise you competently on customised and series production.



### 5.8.2 ipador all-glass door systems

ipador all-glass door systems are elegant solutions for prestigious entrances.

Their transparency is welcoming, their lightness is pleasing, their brilliance is stylish.

Almost everything is possible: single or double pendulum or rebated doors, circular segment or rounded arch doors, always with the option of upper and side elements.

The glass can be clear or coloured, transparent or translucent, with or without structure. Matt surfaces, ground designs and enamel coatings can be applied in different variants for individual effects (see Section 5.9 on ipadecor).

ipador all-glass door systems always consist of high-quality ipasafe thermally toughened safety glass (see Section 5.7.1). This special glass is practically insensitive to thrust and impact and highly resistant to bending stress.

If it is damaged by violent force, it crumbles into small blunt pieces.

The usual glass thicknesses are 10 mm or 12 mm, depending on the dimensions of the all-glass door system. According to the structural requirements, bracing elements may be needed.

An extensive range of fittings allows highly differentiated and diverse functionality.

By varying the surface treatment, the fittings can be harmonised with a great diversity of interior decoration schemes.

Visible glass edges are polished and thus meet the highest expectations.

Overview of types

Manifold combinations (doors, side elements, upper panels) allow the all-glass area to be divided up into fixed and movable elements in many different ways.

The following catalogue of types (1 to 24) documents the wide range of variants.

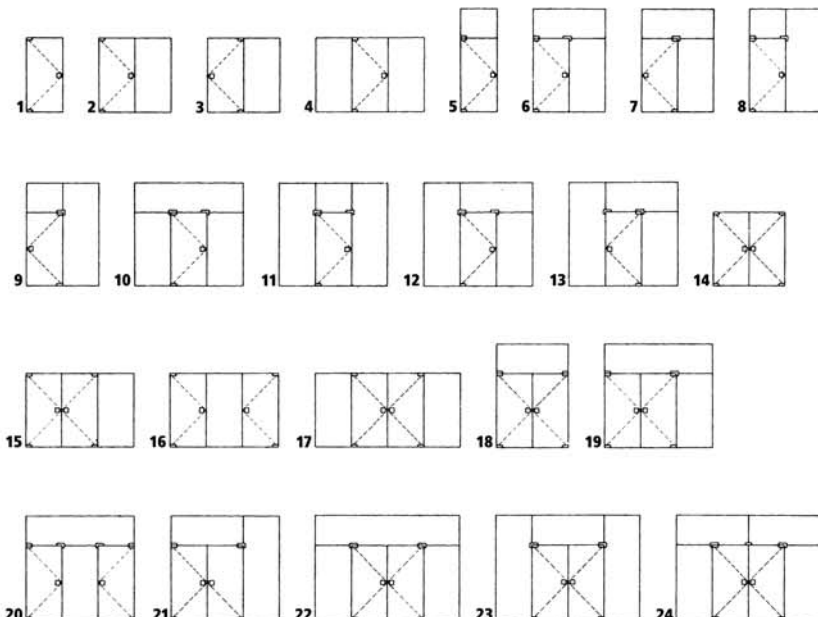

ipador, catalogue

## 5 Description of INTERPANE Products



In addition to the door shapes shown previously, rounded arch doors or circular segment doors can be installed (see following illustrations).

Rounded arch doors

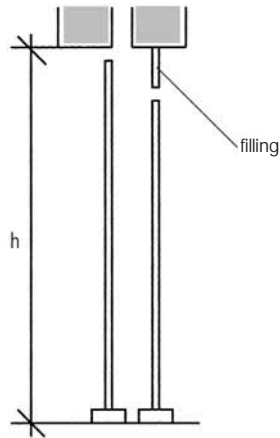
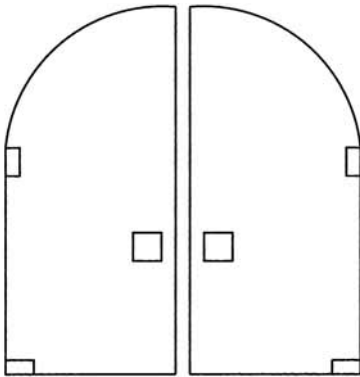

Circular segment doors

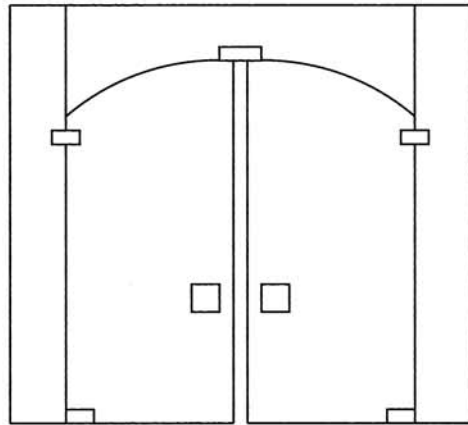
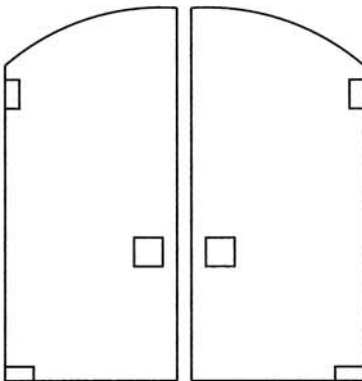

Depending on the wall thickness and maximum door height, a large space between the top of these rounded doors and the wall arch may be necessary so that the door can be opened by 90°. In this case, the air gap should be foreseen in the building construction.

## 5 Description of INTERPANE Products

### Types of doors

Both types of door, pendulum doors and doors in rebated frames, are available.

- Pendulum door

The door can be swung open in both directions.

- Doors in rebated frames

A distinction is made for doors in rebated frames between DIN right and DIN left. The DIN orientation is determined by the direction to which the door can open. The door can open only in one direction (the same door side as the hinge).

pendulum door



door in rebated frame



DIN left



### Bracing glazing

In all-glass door systems, which can consist of several panes, bracing glazing may be necessary due to the glazing dimensions and the distribution of the glazing elements.

If the dimensions of A or B in the diagram are  $\leq 400$  mm, there is no need for bracing glazing, even if the limits indicated on the next pages are exceeded.

The construction of the bracing glazing is determined by structural requirements and building authorities' specifications.

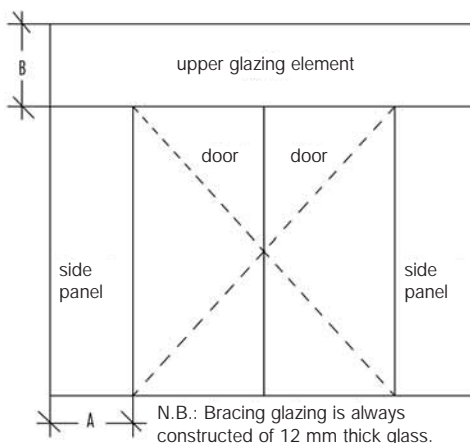



## 5 Description of INTERPANE Products



Dimensioning the bracing glazing as a function of the height of the all-glass door system

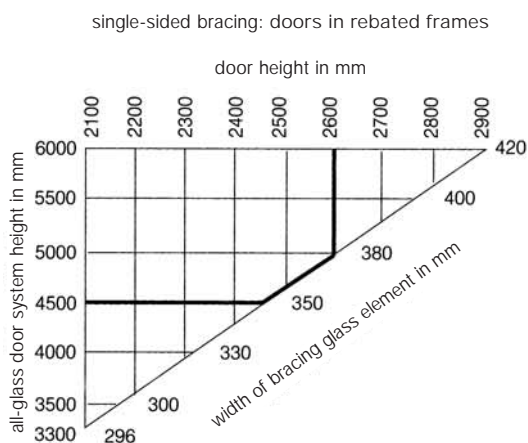
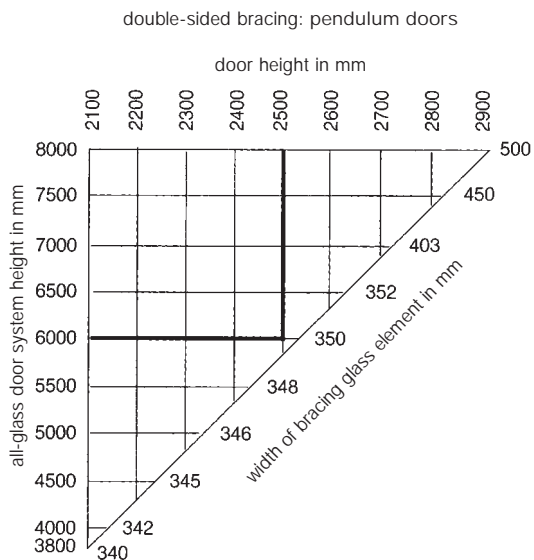

bracing glass elements

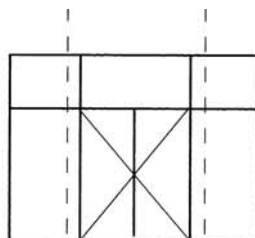

Examples for reading graph:

1. Double-sided bracing:  
Pendulum doors

All-glass door system height  
6000 mm/door height 2500 mm:  
The bracing glass element must  
be 350 mm wide.

2. Single-sided bracing:  
Doors in rebated frames

All-glass door system height  
4500 mm/door height 2600 mm:  
The bracing glass element must  
be 380 mm wide.

N.B. : If a horizontal line is drawn at the height of the all-glass door system, its intersection with the diagonal line determines the width of the bracing glass element. A vertical line upwards from the diagonal identifies the maximum door height for that width of the bracing element. If the door height is greater, the vertical line is displaced to the right along the diagonal until it coincides with the door height.

## 5 Description of INTERPANE Products



Maximum dimensions: Door elements

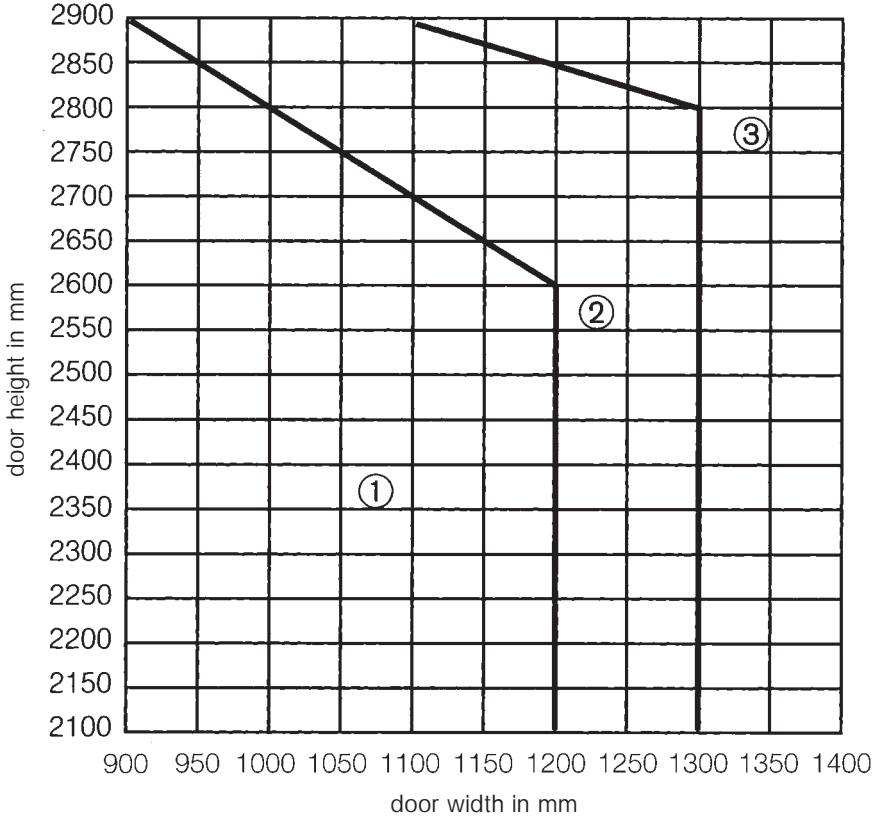

- |   | glass thickness (mm) |
|---|----------------------|
| ① Light metal (LM) hinge above and below                        | 10 or 12             |
| ② Light metal (LM) hinge above and light metal (LM) rail below  | 10 or 12             |
| ③ Consultation with INTERPANE application technology necessary. |                      |

## 5 Description of INTERPANE Products



Standard machining for ipador all-glass door systems	
Door elements	Side panels and upper element
<ul style="list-style-type: none"> <li>● all edges polished</li> <li>● cut-outs for corner fittings</li> <li>● two holes for handles</li> <li>● machining for a lock in the side centre or the corner</li> </ul>	<ul style="list-style-type: none"> <li>● all visible edges polished</li> <li>● cut-outs for corner fittings</li> <li>● machining for lock retaining plate</li> </ul>

Deliverable types of glass for ipador all-glass door systems				
type of glass	colour	glass thickness (mm)		
			10	12
float glass	clear		X	X
float glass	blue		X	-
float glass	bronze		X	X
float glass	grey		X	-
float glass	green		X	-
satin-finished glass	translucent		X	X
SR Silvit 178	translucent		X	-
SR Listral 200	translucent		X	-
Mastercarre	translucent		X	-

In addition to these standard types of glass, ipador all-glass systems can also be delivered with many different decorative patterns.

Tolerances			
	door width (mm)	glass thickness (mm)	
		door height ≤ 2000 mm	door height > 2000 mm
limit for overall bow	300 – 950	1.0	1.5
	951 – 1300	1.5	2.0
tolerance for width and height	door width or height	tolerance (mm)	
	≤ 2500	+ 1.0 / - 2.0	
	> 2500	+ 1.0 / - 2.5	

### 5.8.3 ipador horizontal sliding walls

ipador horizontal sliding walls offer optimum flexibility for varying room dimensions.

The standard version of ipador horizontal sliding walls is manufactured of thermally toughened safety glass made of clear float glass. In addition, the same types of glass and decoration can be used as for ipador all-glass door systems (see Section 5.8.2).

A sophisticated rail system allows complete glass walls, including integrated pendulum doors, to be pushed to the side. The special construction of the sliders means that the elements can be moved very easily, but still offer excellent mechanical stability.

Individual elements can also be pushed around a corner without needing a disturbing floor rail, and can be "parked" in almost any desired position.

Each ipador horizontal sliding wall system is planned, produced and mounted individually according to the needs and desires of the building owner.

Five different elements can be combined with each other.

- ① The revolving door or pendulum door end element is at the end of the system and cannot be pushed aside:
  - pendulum door end element with a floor-mounted door closer or
  - revolving door end element with a door closer mounted on the swivel bearing or the upper edge.

Both variants can be delivered with a lower lock and an upper positioning pin (special production for lock positioned at the side).

Overview of system elements in ipador horizontal sliding walls

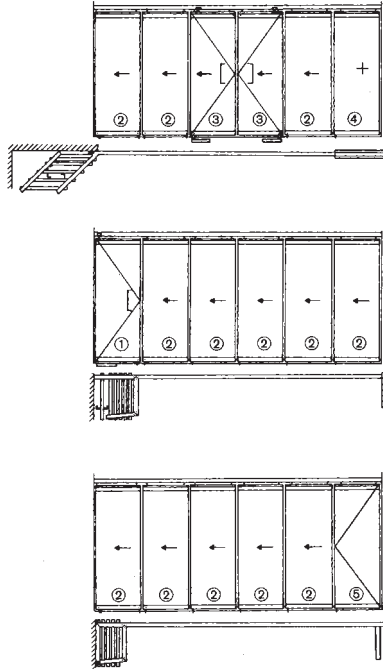

The adjacent figure illustrates examples of three different possible combinations of elements in a sliding wall, each including a floor plan of the elements in the "parked" position.

- ② The sliding element can be positioned anywhere within the sliding wall system.
- ③ The door element, available as a
  - pendulum door sliding element with a floor-mounted door closer
  - pendulum door sliding element with a frame-mounted door closer
  - revolving door sliding element with a door closer mounted on the sliding rails.
- ④ The fixed element can be positioned in accordance with the intended function of the horizontal sliding wall.
- ⑤ The rebate-framed door end element must be positioned at the end of the system, as it cannot be slid, resembling a fixed element in this respect.

It is mainly used where a door is intended to be opened in one direction only.

As the rails can be mitre-cut and mounted, curved rails are not needed. As a result, almost all individual floor-plan concepts can be implemented.

The door elements can be mounted at any position within the system.

## 5 Description of INTERPANE Products



### 5.8.4 iplus HT anti-reflective glazing

Uncoated panes of float glass have a surface reflectance of about 8 %. Coating both surfaces with iplus HT reduces the light reflectance to about 2 %. The surfaces become anti-reflective, resulting in a higher transmittance for incident sunlight.

In thermal applications of solar energy, it is important that the maximum amount of incident solar energy over the entire spectrum be used.

Almost all solar collectors have covers made of glass panes. Some of the incident solar energy is reflected by the glass surfaces. A further amount is absorbed in the glass pane and is radiated outward and inward as heat. These effects reduce the amount of energy which reaches the absorber plate.

Thus, the greatest possible energy transmittance ( $\tau_e$ ) for solar energy and long-term durability are important properties of glass covers for thermal applications of solar energy. The energy transmittance must be increased by reducing the reflectance and absorbance of the pane.

$$\tau_e (\text{max}) = 1 - \rho_e (\text{min}) - \alpha_e (\text{min})$$

Due to the high thermal stresses and mechanical loads experienced, collector covers are made of thermally toughened safety glass.

Conventional cover panes are made of low-absorbance low-iron glass, either with smooth or structured surfaces. If the low-iron glass is coated with iplus HT, the transmittance of the glass is increased due to its anti-reflective property. The 5 % increase in energy transmittance which is achieved in this way automatically raises the solar yield. A further advantage of iplus HT is the weak

angular dependence of the reflectance of the coated glass. This results in a significantly higher transmittance of obliquely

incident radiation during the early morning, late afternoon or the less sunny winter months.

Operating principle of iplus HT - highly transmissive cover glass for solar collectors

uncoated glass

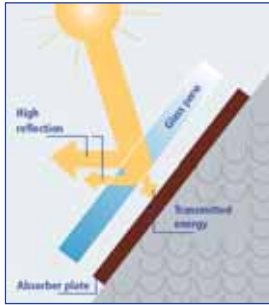

glass coated with iplus HT

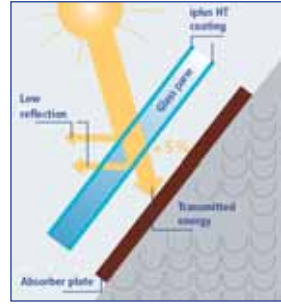

Technical values according to EN 410 for iplus HT on a low-iron glass substrate

	4 mm low-iron glass substrate	4 mm low-iron glass substrate with iplus HT % %
light transmittance $\tau_v$	91	97
light reflectance $\rho_v$	8	2
energy transmittance $\tau_e$	89	94

- Long-term durability

With the coatings being on positions 1 and 2, iplus HT is constantly exposed to severe environmental conditions. It meets the stringent criteria specified in all relevant testing standards (EN 1096, IEC 61 215). The highly transmissive property is stable over the service lifetime. iplus HT is scratch-resistant and can be further machined without difficulties.

also meets the aesthetic demands of modern architecture. The clear view through to the interior of the collector is not obstructed - the appearance is not "diffuse". The transparency of the glass indicates the quality of the collector. Transparency combined with homogeneity makes it possible to use solar-thermal collector areas as design elements.

- Optical performance

In addition to increasing the energy yield and reducing the angular dependence compared to structured glass, iplus HT

## 5 Description of INTERPANE Products



### 5.8.5 ipasafe construction glass

Contemporary architecture features glass that is used, not only as a design element, but also as a structural building component with load-bearing functions.

Today, increasingly large areas of the building envelope are glazed and as a result, parts of the sub-structure are more often visible. Consequently, the demands regarding precise construction work are significantly higher than in the past.

The glazing products which are needed for this type of construction must comply with still narrower tolerance limits than are specified in DIN standards.

Narrower tolerance limits form the basis for achieving excellent visible quality with the entire construction. Parallel joints, regular grid patterns of joints, accurate corner intersections and optimal planarity meet the highest expectations.

INTERPANE has developed "ipasafe construction glass" for these prestigious glazed constructions. ipasafe construction glass is distinguished by appreciably narrower tolerances on dimensions. These are monitored for the final product according to a testing plan.

With ipasafe construction glass, installation becomes a simple and cost-effective task for the façade builder.

The essential product features of thermally toughened safety glass, heat-strengthened glass and laminated safety glass are optimised for ipasafe construction glass. In addition, the production is subject to both in-house and third-party surveillance.

The tolerances and properties of ipasafe construction glass are presented in the following tables.

## 5 Description of INTERPANE Products



Tolerances for ipasafe construction glass

properties \ product	tolerances	
	6 mm to 12 mm thermally toughened safety glass or heat-strengthened glass	15 mm and 19 mm thermally toughened safety glass
width or length		
≤ 200 cm	± 1.0 mm	± 1.5 mm
≤ 300 cm	± 1.0 mm	± 2.0 mm
≤ 400 cm	± 1.5 mm	± 2.5 mm
≤ 500 cm	± 2.0 mm	± 3.0 mm
deviation of the diagonals		
≤ 200 cm	± 1.0 mm	± 1.5 mm
≤ 300 cm	± 1.5 mm	± 2.0 mm
≤ 400 cm	± 2.0 mm	± 2.5 mm
≤ 500 cm	± 2.5 mm	± 3.0 mm
flatness	1.5 mm/m	
local bow over 300 mm length	0.15 mm	
relative position of holes to each other	± 0.5 mm	
edge quality	ground, smoothly ground or polished	
pane format	rectangular formats	
minimum dimensions	300 mm x 450 mm	
maximum dimensions	2600 mm x 4200 mm	
heat-soak test on demand	according to EN 14 179 and/or BRL A	

properties \ product	tolerances on laminated safety glass (VSG) made of 2 heat-strengthened panes (TVG)			
	VSG 12/2 of 2 x TVG	VSG 16/2 of 2 x TVG	VSG 20/2 of 2 x TVG	VSG 24/2 of 2 x TVG
width or length				
≤ 200 cm	± 2.0 mm			
≤ 300 cm	± 2.0 mm			
≤ 400 cm	± 2.5 mm			
≤ 500 cm	± 3.0 mm			
relative position of holes to each other	± 1.0 mm			
displacement of edges and holes	1.0 mm			
edge quality	ground, smoothly ground or polished			
pane format	rectangular formats			
minimum dimensions	300 mm x 450 mm			
maximum dimensions	2600 mm x 4200 mm			

EOL

### 5.8.6 Processing for glass support systems

Support systems for glazing edges

Use of the glass edge to structurally attach glazing elements has opened up possibilities for novel glazing systems.

The glass edge can be milled to produce specific profiles according to the glass material used. This makes a form-fitted and friction-locked connection feasible between the glass and the substructure.

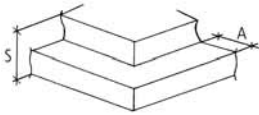

ipasafe thermally toughened safety glass or heat-strengthened glass with milled edges

ipasafe thermally toughened safety glass or heat-strengthened glass can be produced with edges finished in various step and bevelled profiles and with milled notches. INTERPANE must be consulted about the form in each individual case.



ipasafe thermally toughened safety glass or heat-strengthened glass with a joint support system

Point-supported glazing elements

Point supports can also be implemented as an alternative to classic methods of supporting glazing elements.

These glazing elements are usually produced out of thermally toughened safety glass or laminated safety glass made of thermally toughened safety glass or heat-strengthened glass.

Depending on the type of support, either countersunk or cylindrical holes can be used.

Point-supported glazing elements offer the visible advantages of a frameless glazing element without the need for complicated adhesive attachment and substructures.

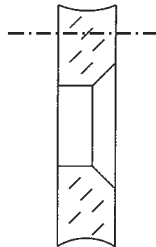

ipasafe thermally toughened safety glass or heat-strengthened glass with countersunk hole

Due to the special type of attachment, it is not only the load on the centre of the glazing which is important. The forces acting in the zone around the holes through the glass are at least equally important.

ipasafe glazing elements with holes feature high-quality finishing of the hole surfaces. This guarantees that the pane will be supported reliably.

These ipasafe glazing elements can also be delivered as construction glass, both as monolithic elements and as insulating glass units (IGU). In the IGU variant, the load on the edge seal must also be taken into account due to the specific stress distribution.

For simple point-supported vertical or overhead glazing, the technical guidelines for dimensioning and producing point-supported glazing can be applied. In more complex cases, specific authorisation for the individual case is still required.

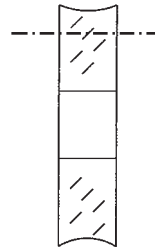

ipasafe thermally toughened safety glass or heat-strengthened glass with cylindrical hole

## 5 Description of INTERPANE Products



Construction examples for bolted ipasafe glazing elements

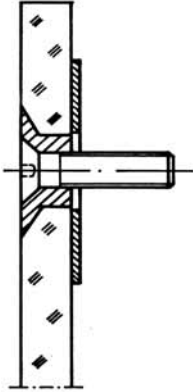

Counter-sunk fixing bolt

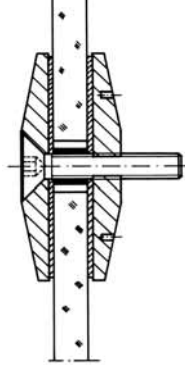

Spider clamp

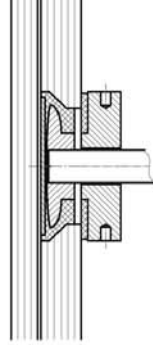

Anchor fixing into laminated glass

## 5 Description of INTERPANE Products



### 5.8.7 ipatec point-supported canopy systems and overhead glazing

Protected by glass and stainless steel

Support systems and fittings made of high-quality, weather-resistant stainless steel can be used to design an individual, elegant and functional entrance - the first impression conveyed by a commercial building or a private house. The timeless stylish appearance of a glass canopy harmonises with every building style.

General permit by building inspection authorities (AbZ = allgemeine bauaufsichtliche Zulassung)



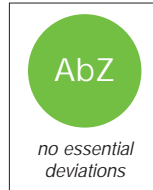

The general permit by building inspection authorities for glass canopy systems means that no further structural calculations, no building component testing and no specific authorisation for the individual case are required.



## 5 Description of INTERPANE Products

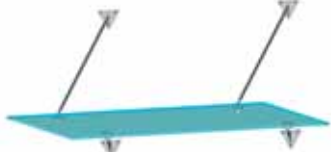
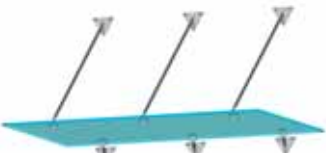

Safety with general permit by building inspection authorities (AbZ = allgemeine bauaufsichtliche Zulassung)





	article number	article name	safety
	1945VA	"Basic" set of 2	complete system AbZ No. 70.3-85
	1944VA	"Basic" set of 3 *	complete system AbZ No. 70.3-85
	1855VA	"Triangel" set of 2	complete system AbZ No. 70.3-85
	1854VA	"Triangel" set of 3 *	complete system AbZ No. 70.3-85
	1865VA	"Diamont" set of 2	complete system AbZ No. 70.3-85
	1864VA	"Diamont" set of 3 *	complete system AbZ No. 70.3-85

\* see example on page 207

## 5 Description of INTERPANE Products

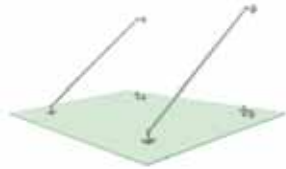

Safety with general permit by building inspection authorities (AbZ = allgemeine bauaufsichtliche Zulassung)

	article number	article name	safety
	1985VA	"Informo" set of 2	no essential deviations from AbZ No. 70.3-85 complete system
	1984VA	"Informo" set of 3	no essential deviations from AbZ No. 70.3-85 complete system
	1875VA	"Tec" set of 2 *	no essential deviations from AbZ No. 70.3-74 complete system for point supports and glass + structural specifications of substructure
	1874VA	"Tec" set of 3	no essential deviations from AbZ No. 70.3-74 complete system for point supports and glass + structural specifications of substructure

\* see example on page 209

## 5 Description of INTERPANE Products



Technical information on AbZ 70.3-85

Maximum dimensions for 1944VA, 1854VA and 1864VA

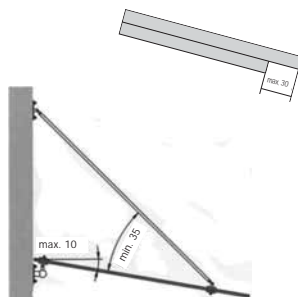
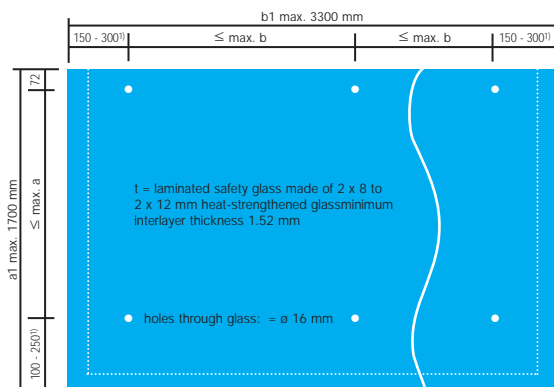

A drip edge with a maximum width of 30 mm can be applied along the free sides of the flat pane (see dotted line).

Overview of dimensions for 6-point support systems  
(systems with 4-point supports are also deliverable)

maximal a	maximal b	corresponding glazing configuration	maximal snow load	diameter of area around hole without enamel coating
928 mm	1,200 mm	laminated safety glass = 2 x 8 mm heat-strengthened glass	1.00 kN/m <sup>2</sup>	‰140 mm
1,128 mm	1,350 mm	laminated safety glass = 2 x 10 mm heat-strengthened glass	1.00 kN/m <sup>2</sup>	‰140 mm
1,228 mm	1,200 mm	laminated safety glass = 2 x 10 mm heat-strengthened glass	1.00 kN/m <sup>2</sup>	‰140 mm
1,228 mm	1,200 mm	laminated safety glass = 2 x 10 mm heat-strengthened glass	0.75 kN/m <sup>2</sup>	‰ 70 mm
1,378 mm	1,350 mm	laminated safety glass = 2 x 10 mm heat-strengthened glass	0.75 kN/m <sup>2</sup>	‰140 mm
1,378 mm	1,350 mm	laminated safety glass = 2 x 12 mm heat-strengthened glass	1.00 kN/m <sup>2</sup>	‰140 mm
1,378 mm	1,350 mm	laminated safety glass VSG = 2 x 12 mm TVG heat-strengthened glass	0.75 kN/m <sup>2</sup>	‰ 70 mm

1) The distances to the edges must be different, the difference in distance must be at least 15 mm.

F 07

## 5 Description of INTERPANE Products



### ipatec overhead glazing with general permit

by building inspection authorities (AbZ = allgemeine bauaufsichtliche Zulassung)

More safety and simple planning for overhead glazing.

Entire roofscapes of glass can be designed on the basis of the new general permit by building inspection authorities - no structural load calculations, no building component testing and no specific authorisation for the individual case are required.

Drip edges, ceramic or printed surfaces - no problem!

The mechanical load limit, e.g. due to snow, is  $1.16 \text{ kN/m}^2$ , the limit for wind suction loads is  $2 \text{ kN/m}^2$ .

As the examples show, there are numerous and diverse application areas - from a few square metres to roofs that are 80 m long.

Overhead glazing can be designed simply and quickly by use of the permit number Z-70.3-74 (for three types of point support) and any type of substructure.

The point-supported models can be mounted either above or below the glass for every type of substructure.



## 5 Description of INTERPANE Products

Technical information on AbZ 70.3-74

Maximum dimensions

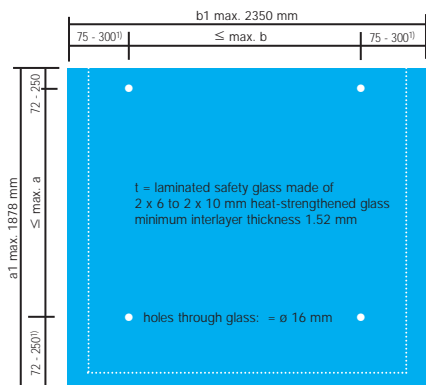

Overview of dimensions for 4-point support systems  
(systems with 6-point supports are also deliverable)

maximal a	maximal b	corresponding glazing configuration	maximal mechanical line load	diameter of area around hole without ceramic coating
928 mm	1,150 mm	laminated safety glass = $2 \times 6$ mm heat-strengthened glass	1.163 kN/m <sup>2</sup>	$\geq 140$ mm
928 mm	1,400 mm	laminated safety glass = $2 \times 8$ mm heat-strengthened glass	1.163 kN/m <sup>2</sup>	$\geq 140$ mm
928 mm	1,400 mm	laminated safety glass = $2 \times 8$ mm heat-strengthened glass	0.913 kN/m <sup>2</sup>	$\geq 70$ mm
1,378 mm	1,350 mm	laminated safety glass = $2 \times 10$ mm heat-strengthened glass	1.163 kN/m <sup>2</sup>	$\geq 70$ mm
1,178 mm	1,650 mm	laminated safety glass = $2 \times 10$ mm heat-strengthened glass	1.163 kN/m <sup>2</sup>	$\geq 70$ mm
1,328 mm	1,750 mm	laminated safety glass = $2 \times 10$ mm heat-strengthened glass	0.913 kN/m <sup>2</sup>	$\geq 70$ mm

<sup>1)</sup> The distances to the edges must be different, the difference in distance must be at least 15 mm.

### 5.8.8 ipasafe S flooring glass

Glazed areas that can be walked upon form very effective accents in an interior design.

The basic glazing configuration consists of laminated safety glass with an upper protective pane of thermally treated glass (thermally toughened safety glass or heat-strengthened glass), which can include coloured design options, and the lower load-bearing glass laminate.

The following points should be noted in the application of flooring glass:

- The glass panes must be laid on a flat and inflexible substructure.
- The glass panes should be mounted on all sides on an underlay of material with hardness in the range between 60 and 70 Shore A. Glass-glass or glass-metal contact is forbidden.
- The underlay under the glass edges should be about 30 mm thick.
- As a minimum requirement, the edges should at least be arched. Other forms of edge finishing are preferable.
- To prevent sliding, the glass surface should be ordered with an anti-sliding screen-printed coating in accordance with regulations for workplaces.
- The glass surface is susceptible to scratching.
- Steps which are supported on two sides must be dimensioned individually. Residual structural stability must be proven by building component testing.
- The required glass thicknesses for glass panes that are supported on four sides can be determined from the following diagram in accordance with the area and point loads.

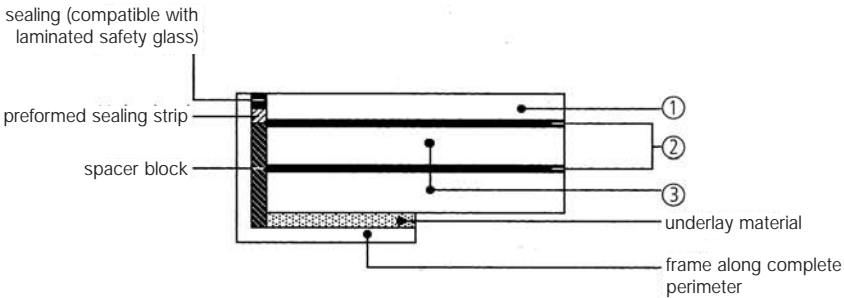

- ① Protective pane which protects the load-bearing glass laminate against damage. The protective pane is at least 6 mm thick in all glazing configurations and usually consists of thermally treated glass (thermally toughened safety glass or heat-strengthened glass) with or without a printed coating. This pane is not considered to be load-bearing for the calculations.
- ② PVB interlayers
- ③ The load-bearing glass laminate consists of two or three glass panes.

Fig. 1 Pane configuration and recommendations for installation

## 5 Description of INTERPANE Products



Diagram to dimension flooring glass which is supported on four sides

Boundary conditions: Permissible mechanical stress (tensile bending): 15 N/mm<sup>2</sup> for float glass according to technical guidelines for linearly supported glass



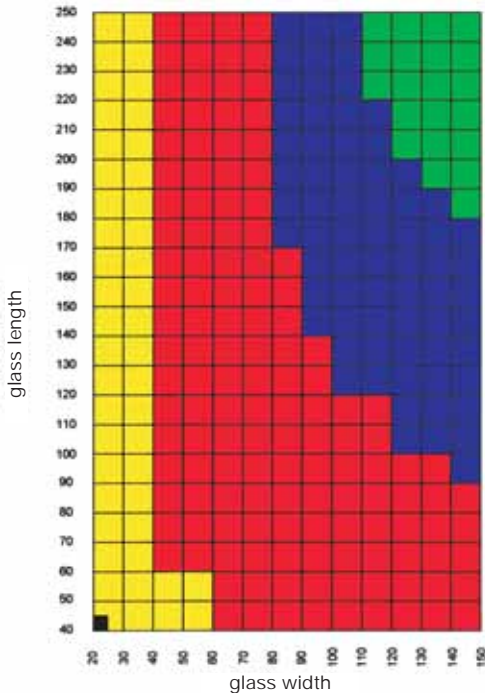

Permissible sag: 1/200

Load: 5 kN/m<sup>2</sup> load per unit area + dead load  
2 kN over 10 cm x 10 cm (centre of element) + dead load

The diagram was calculated according to the technical guidelines for linearly supported glazing presented in Section 7.7.1.



The diagram was checked by a structural engineer and a structural engineering inspector. Building component tests for the least favourable configurations were carried out in accordance with the recommendations of the German Institute for Building Technology (DIBt) for flooring glass. The technical documents can be requested from INTERPANE Sicherheitsglas in Hildesheim.

	product	mass [kg/m <sup>2</sup> ]	thickness [mm]	thickness tolerance [mm]
	ipasafe S26	67	28	± 2
	ipasafe S30	77	32	± 2
	ipasafe S36	93	39	± 2
	ipasafe S44	113	47	± 2

Minimum pane dimensions: 250 mm x 450 mm

Flooring glass should not be confused with glazed areas which may be walked on e.g. for maintenance and cleaning purposes (e.g. glass roofs, etc.). These types of glazing must conform to the testing principles specified in GS-BAU-18 (February 2001) by the main association of German trade organisations (HVBG).

## 5 Description of INTERPANE Products



### 5.8.9 Glazing for lifts / elevators

Glazed lift systems are distinctive features of modern architecture. Glass-walled lifts convey the impression of lightness and effortless floating.

Implementation of these modern glass construction concepts demands that a series of guidelines, regulations and ordinances be observed.

As a general principle, the German lift ordinance (AufzV) 6/98 and the European lift guideline 95/16 EG 7/99 must be observed.

In addition, the EN 81 02/99 standard with the title "Safety rules for the construction and installation of lifts" applies.

Furthermore, the legal regulations of the State building authority in each German state apply to the walls surrounding the lift shaft.

Different specifications apply to the lift cabin itself and the lift shaft.

Requirements on the walls of the lift shaft

If glass is installed in the walls of a lift shaft, EN 81 demands proof of structural stability under attack by a force of 300 N on a round or square area of 5 cm<sup>2</sup>. If lift shaft walls are exposed to wind loads, these must also be taken into account in the proof of structural stability.

Requirements on the walls of the lift cabin

- laminated safety glass made of thermally treated glass (VSG-V) minimum thickness: 8 mm + 0.76 mm PVB interlayer
- laminated safety glass minimum thickness: 10 mm + 0.76 PVB interlayer



- laminated safety glass made of thermally treated glass (VSG-V) minimum thickness: 10 mm + 0.76 mm PVB interlayer
- laminated safety glass minimum thickness: 12 mm + 0.76 PVB interlayer

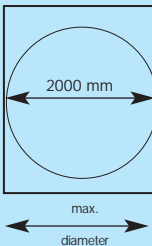

The specifications apply for linear support of the glass panes on all sides.

If the lower edge of the glass areas is less than 1.1 m above the floor of the lift cabin, a load-bearing hand-rail must be mounted at a height between 0.9 m and 1.1 m. It may not be attached to the glass.

Requirements on the sliding doors

- support along 2 edges, upper and lower laminated safety glass made of thermally treated glass (VSG-V)

minimum thickness: 16 mm + 0.76 mm PVB interlayer  
width: 360 mm to 720 mm  
door height: clear height max. 2100 mm

- support along 3 edges, upper, lower and one side laminated safety glass

minimum thickness: 16 mm + 0.76 mm PVB interlayer  
width: 300 mm to 720 mm  
door height: clear height max. 2100 mm

- support along all edges laminated safety glass

minimum thickness: 10 mm + 0.76 mm PVB interlayer  
width: 300 mm to 870 mm  
door height: clear height max. 2100 mm

Labelling

According to EN 81, the glass panes must be labelled with at least the following information:

- name of the manufacturer / product name
- type of glass (laminated safety glass or laminated safety glass made of thermally treated glass VSG-V)
- thickness (e.g. 5/5 / 0.76)

### 5.9 ipadecor - design options for glazing surfaces

Prestigious architecture with large glazed areas offers practically unlimited opportunities for planners and artists to vary the colour, form, pattern and structure. In the hands of a creative architect, the façade can be the backdrop for artistic design.

The confines of rectangular structural units can be overcome by playing with colours and patterns, and geometric and free design forms. Creative design of the individual elements transforms the building to a piece of art.

The interaction between glass and light - in reflection, transmission and absorption - opens up aesthetic and light-design effects which can be mixed and matched with each other.

The public building sector, and similarly the commercial and industrial sectors, have long since discovered and applied this diversity of design.

However, not only large commercial and public buildings are suitable objects for modern glass design; there are also manifold possible applications in private housing.

The noble material, glass, already appears in a new light if a simple design is added.

The great durability of glass makes it permanent for generations.

Nevertheless, glass design demands considerable expertise - "glass does not forgive errors".

INTERPANE, as an innovative partner, can support you with its long years of experience in realising your dreams in glass: creatively, constructively, competently!

Processes for designing on glass

Today's possibilities for producing designs on glass are greater than ever before.

On the one hand, well-established and proven processes such as classic screen-printing or sand-blasting are available. On the other hand, completely new approaches to glass design have arisen, including ceramic digital printing.

It is precisely this combination of established and innovative processes which can achieve results that would have been inconceivable only a short time ago.

INTERPANE offers its commercial partners a comprehensive range of products and design processes, which are marketed under the brand name of ipadecor.

The processes described on the following pages can be combined in almost unlimited ways with each other. The designs can be applied in combination with float glass, thermally toughened glass, heat-strengthened glass, laminated safety glass and insulating glass units.

### Process technology for designs on glass

#### Ceramic digital printing

High-resolution reproduction of illustrations, patterns etc. in colour.

Dimensions / Mass	
max. dimensions	260 cm x 370 cm
min. dimensions	20 cm x 30 cm
glass thickness	4 mm to 19 mm
max. mass	500 kg

The newest technology allows photorealistic illustrations to be produced with ceramic pigments.

Designs have now become feasible, which could not be implemented with screen-printing. In addition, ceramic digital printing can be combined with screen-printing, offering creativity yet another option.

As no screens have to be prepared, there are no longer any limits to individuality, which can express itself differently on each individual pane, if desired.

Ceramic digital printing with "ipadecor C4 color management" by INTERPANE / Hoffmann GTD.

Few colours are needed to obtain many colour nuances, also some beyond the RAL and NCS palettes, yet still well-defined and reproducible.

With the help of the "ipadecor C4 color management" colour cube, realistic colour hues can be selected.



## 5 Description of INTERPANE Products



Ceramic screen-printing  
Ceramic pigments fired onto glass,  
weather-resistant, coloured, white,  
black (opaque), etch effect,  
non-slip (translucent)

Dimensions / Mass	
max. dimensions	150 cm x 330 cm
min. dimensions	20 cm x 30 cm
glass thickness	4 mm to 19 mm
glass thickness	120 kg

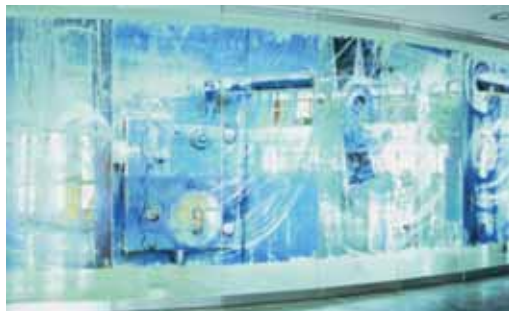

Sand-blasting  
Refined matt surfaces, satin finish,  
engraving, reliefs,  
over the whole surface or in segments,  
ornaments, pictures, text,  
with fingermark protection if desired

Dimensions / Mass	
max. dimensions	200 cm x 300 cm
min. dimensions	20 cm x 30 cm
glass thickness	3 mm to 19 mm
glass thickness	120 kg



## 5 Description of INTERPANE Products



### Fluted beveling

High-quality ornaments and patterns with matt or polished fluted beveling.

Fluted beveling with V-formed, C-formed and asymmetric profiles can be delivered.

Dimensions / Mass	
max. dimensions	230 cm x 420 cm
min. dimensions	20 cm x 30 cm
glass thickness	4 mm to 19 mm
max. mass	350 kg



### Coloured laminated glass

Laminated safety glass with transparent or translucent coloured interlayers.

The combination of different basic colour hues results in a practically unlimited colour palette.

Dimensions / Mass	
max. dimensions	155 cm x 600 cm
min. dimensions	25 cm x 45 cm
glass thickness	6 mm to 24 mm
max. mass	1000 kg



## 5 Description of INTERPANE Products



### Veneer-glass laminates

Veneers of many different types of materials can be laminated behind or between glass with a special process. The veneer materials are available in numerous decorative variants. Sophisticated composite materials result, which are easy to clean and provide permanent protection for the decorative surface.

Dimensions / Mass	
max. dimensions	100 cm x 400 cm
other dimensions on request	
min. dimensions	20 cm x 30 cm
glass thickness	4 mm to 20 mm
max. mass	120 kg



### Photo/slide glass laminates

Photographic reproductions which meet the highest demands are protected permanently against environmental agents (UV, moisture, etc.) in a glass laminate. The accurate reproduction leads to probably the best presentation form for photographic display objects

Particularly suitable for museums, private collections, etc.

Dimensions / Mass	
max. dimensions	98 cm x 300 cm
other dimensions on request	
min. dimensions	20 cm x 30 cm
glass thickness	4 mm to 20 mm
max. mass	120 kg



### Advice on processes for design on glass

To facilitate selection among the diverse range of possibilities, INTERPANE Sicherheitsglas (Safety Glass) in Hildesheim offers technical design consultancy to interested customers by a glass design studio and trained advisors.

This simplifies communication between designers and producers and allows creative processes to be implemented in co-operation between the partners.

The newest technology for image processing and design creation makes modern design feasible and optimises the development process.

### 5.10 ipaview CF - intelligent liquid-crystal glazing for controllable privacy

Convincing transparency, opaque privacy screening or an eye-catching display - ipaview CF makes glazing multi-functional. ipaview CF from INTERPANE stands for a controllable liquid-crystal glass laminate: a liquid-crystal film and two indium tin oxide films sandwiched between float glass panes.

With its integrated grid connection, ipaview CF allows transparency to be controlled at the press of a button. When voltage is applied, the liquid crystals become ordered - the glass appears transparent to the eye, although with a slight angular dependence. When the power is turned off, the crystal structure appears milky white - the glazing unit obstructs the view in both directions and can function as a display and advertising space with rear-projected images.

Whether as an intelligent screen system for open-plan offices, a flexible element for reception and conference rooms to create a conducive atmosphere, the glazing for bank counters with additional safety features, or the basis for an eye-catching product presentation at a trade fair or in a shop window - ipaview CF opens up completely new functions and perspectives.

#### Features

- transition from transparent to milky at the press of a button
- usable as a display and screen: possible with beamers
- low electricity consumption
- maximum safety with minimal maintenance

#### Applications

- as an intelligent room divider and screen
- as an optical barrier for personal safety and product protection
- for trade fair and shop displays
- for outdoor advertising and displays
- as a rear-projection screen for conference rooms and auditoriums
- usage in insulating glass units is currently being prepared

#### Dimensions

- maximum glass dimensions 980 mm x 3000 mm
- customised special dimensions possible
- can be combined to provide a large-area glass frontage

#### Product variants

- as laminated glass
- in combination with most common types of glass



## 5 Description of INTERPANE Products



### Technical data

switching voltage:	AC 110 V
power demand:	app. 7 W/m <sup>2</sup>
frequency:	50 Hz to 60 Hz
current demand:	app. 0.1 A/m <sup>2</sup>
switching time:	≤ 1 s
switching cycles:	> 3 000 000
operating temperature range:	-20 °C to +60 °C
geometrical forms:	all square and rectangular forms

Deliverable as laminated glazing made of thermally toughened glass, heat-strengthened glass or float glass

Deliverable dimensions: max. 980 mm x 3000 mm  
min. 200 mm x 300 mm

max. mass: 120 kg

Several switchable films can be applied side-by-side, making larger dimensions also possible. Along the joint, a clear gap with a width of 4 mm to 6 mm is visible.

Laminated glass type: 10/2 total thickness: 11 mm ± 1 mm

8/2 total thickness: 9 mm ± 1 mm

### Example of configuration:

4 mm glass/adhesive film/liquid-crystal film/adhesive film/4 mm glass

	transparent	translucent
$\tau_v$	app. 79%	app. 70%
$\tau_{uv}$	app. 4%	app. 3%
$\tau_e$	app. 68%	app. 61%
g value	app. 74%	app. 69%

Transparent switching state:  
good viewing properties, not completely transparent, slight angular dependence

Translucent switching state:  
obstructs view, good screen for rear projection

Delivered power supply:  
transformer with primary and secondary wiring

## 5 Description of INTERPANE Products



### 5.11 Fire resistance

Precautionary fire protection measures in buildings are divided into

- prevention of a fire starting
- confinement of the area affected by a fire after it has broken out.

DIN 4102 - fire behaviour of building materials and building components - contains the definitions, classifications and test regulations with respect to fire resistance for building materials and building components.

Normal glass is only of limited use for fire protection.

In the case of fire, if heat is applied from one side to float glass panes, they quickly shatter and large pieces of broken glass fall out. Fire can leap through the opening and quickly spread into the next fire zone.

The increasing application of glass in buildings for façades, spandrel elements and dividing walls has resulted in stricter regulations concerning precautionary fire protection measures.

#### Application area

Fire-resistant glazing in buildings prevents destructive fire from occurring and spreading. It is applied in accordance with the German model building ordinance (Musterbauordnung - MBO) and allows the fire to be extinguished effectively and lives and property to be saved.

This means

- securing emergency access routes
- preventing flames from spreading
- separating building fire zones
- protecting life and property and
- allowing buildings to be evacuated

by use of the transparent building material, glass.

In addition to these requirements, which are regulated in building ordinances and are defined by building inspection authorities for each individual case, architectural aspects determine further specifications for the fire-protection systems with regard to

- aesthetics and safety
- multiple functions in the façade
- large areas for individual panes and
- simplification of glazing installation systems.

As a result, natural daylight can enter a building while the requirements on fire protection are fulfilled almost invisibly.

Fire resistance systems and their classification

The test requirements for standardised burning tests are defined (at the time of writing) in DIN 4102, Fire behaviour of building materials and building components, in Parts 5 and 13. According to the tests passed, a distinction is made between:

- Fire resistance class G

Light-transmitting building components in vertical, tilted or horizontal orientations, which are intended to prevent only the spreading of fire and

smoke for a period of time according to the classified fire resistance duration. The transmission of thermal radiation is only impeded, not prevented.

Classification:

G30, G60, G90, G120 (G120 means a fire resistance duration of 120 minutes).

Glass types used:

- specially thermally toughened float glass
- thermally toughened borosilicate glass
- laminated glass with fire-resistant interlayers.

- Fire resistance class F

Light-transmitting building components in vertical, tilted or horizontal orientations, which are intended to prevent not only the spreading of fire and smoke but also the transmission of thermal radiation for a period of time according to the classified fire resistance duration.

Classification:

F30, F60, F90, F120

Glass types used:

- thermally toughened fire-resistant glass with a gel filling
- multi-pane laminated glass with fire-resistant interlayers.

Glazing with either F or G classification is always mounted as fixed glazing. It must always be tested and used as part of a complete fire-protection system consisting of the glass, frame, sealant and fixed mounting. The fire-resistant glazing can be further processed by specially authorised producers into double glazing units or laminated glass. In doing so, the authorisation requirements must be observed.

## 5 Description of INTERPANE Products



### ● Fire resistance class T

Building components constructed as self-closing doors with or without glazing, so-called fire zone barriers authorised by building inspectors, which are intended to prevent not only the spreading of fire and smoke but also the transmission of thermal radiation for a period of time according to the classified fire resistance duration.

In addition to proof of the burning behaviour, these building components must pass a continuous performance test.

Classification:

T30, T60, T90, T120, T180

In addition, T-classified building components are subject to separate quality control.

Depending on the application, for example in corridors, further standards and ordinances may apply concerning access safety, e.g. regulations for public meeting rooms or workplaces. The same applies for applications in the façade.

Beyond this, the application of European standards (EN) is required in individual cases.

### New European standardisation

The currently valid German testing and classification standard, DIN 4102, will be replaced after a transitional period by the new procedure for testing and classifying fire-resistant building materials according to

- DIN EN 1363 Fire resistance tests, general requirements

### Classification according to DIN EN 13 501

Class E:

No flames or ignitable gases on the side of the building component away from the fire

INTEGRITY

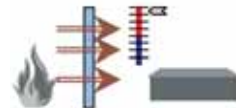

Class EW:

as for Class E. In addition, the transmittance of thermal radiation may not exceed 15 kW/m<sup>2</sup>

RADIATION

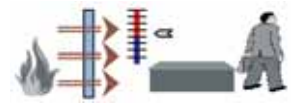

Class EI:

Heat shield function. On average, the temperature of the glass surface away from the fire may not increase by more than 140 K

INSULATION

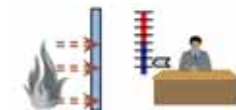

Until the European standard has been incorporated into the German building regulations, the old G, F and T classifications will remain in force.

## 5 Description of INTERPANE Products



### Proof of utilisability

The general German proof of utilisability of fire protection systems on site is the "General permit by building inspection authorities", example Z 19.14-1436. The specific features of the fire-resistant glazing, including detailed drawings of the system, the production and labelling of the building products used and the in-house and third-party inspection regulations for the glass panes used, are described in the permit documentation.

The permit documentation must be present at the application site. The professional company responsible for installing the fire-protection system must supply the building owner with a declaration of conformity concerning correct installation in accordance with the authorisation specifications, which should be forwarded to the relevant building inspection authority, if required.

### Labelling

The German "General permit by building inspection authorities" requires permanent and unambiguous labelling of both the fire-resistant glazing and the complete fire protection system. The following regulations must be observed:

– Fire-resistant glazing:

Etched or ceramic stamp with:

name of the manufacturer  
(e.g. INTERVER)  
product name  
(e.g. INTERFLAM ® E)  
glass thickness  
(e.g. 6 mm)

– Fire protection system:

Steel plate label with:

type of glazing  
(e.g. INTERFLAM ® E 03)  
fire resistance class  
(e.g. G30)  
name or identification code  
of the manufacturer  
permit number  
(e.g. Z 19.14-1436)  
year of production

The label is to be screwed onto the frame of the fire-resistant glazing.

CE label for fire-resistant glazing

If the standards for a product have been completely harmonised within the EU, the product must carry a CE label. For glass intended for use in fire-resistant glazing, this labelling has been voluntary since 1st March 2006 and obligatory since 1st March 2007. As the implementation of the labelling requirement occurs on a national basis, at present (September 2007) during the so-called co-existence phase both the CE label and the national "Ü" symbol are valid in Germany.

The INTERVER products, INTERFLAM ® and INTERFIRE ®, conform with the German technical standards, as indicated by the "Ü" symbol. Furthermore, the INTERFLAM ® E and INTERFLAM ® EW products are subject to quality control as glass products and are labelled according to the CE requirements in EN 12 150, System 3, by the notified body, MPA NRW.

In addition, for the product types INTERFLAM ® EW and INTERFIRE ® EI, which have transparent fire-resistant interlayers, the CE label according to EN 14 449 is registered with the internationally notified body, ectectis, for fire resistance duration periods of up to 120 minutes. ectectis also carries out the obligatory factory inspection for these products. The relevant declarations of conformity can be provided by INTERVER on request. The delivered glass is marked with a permanent stamp and the delivery documents conform with the relevant regulations.

## 5 Description of INTERPANE Products



### INTERVER delivery programme for INTERFLAM<sup>®</sup> E and INTERFLAM<sup>®</sup> EW fire-resistant and safety glazing

#### Basic Standards:

Fire tests in accordance with national norms and EN Standard EN 1363/1364 as well as certificates according EN 13501-2. Detailed information about tested sizes and frames systems in each country are available on our actual element overview.

	Thickness of glass (mm)	Thickness of element (mm)	Spacer (mm)	Lightransmission in %	G-Value in %	b-factor (shading coefficient)	Soundreduction in dB	U-Value in W/m <sup>2</sup> K	max. size of production in cm	min. size of production in cm	weight in kg/m <sup>2</sup>
<b>Single glass</b>											
<b>INTERFLAM E</b>	5	5	-	90	86	0,98	28	5,8	200 x 355	25 x 35	12,5
	6	6	-	89	85	0,97	30	5,8	200 x 355	25 x 35	15,0
	8	8	-	88	85	0,96	32	5,8	200 x 355	25 x 35	20,0
	10	10	-	88	84	0,93	34	5,8	200 x 355	25 x 35	25,0
	12	12	-	87	80	0,93	35	5,8	200 x 355	25 x 35	30,0
<b>INTERFLAM EW</b>	6	6	-	83	75	0,86	30	3,6	200 x 355	25 x 35	15,0
<b>Laminated glass</b>											
<b>INTERFLAM E</b>	5 / 5	10,8	-	86	76	0,87	35	5,8	160 x 320	25 x 35	25,0
	6 / 6	12,8	-	86	75	0,86	38	5,8	160 x 320	25 x 35	30,0
<b>INTERFLAM EW</b>	6 / 6	12,8	-	70	68	0,78	38	3,6	160 x 320	25 x 35	30,0
<b>Sealed units</b>											
<b>INTERFLAM E</b>	6 / 6	≥ 20	≥ 8	82	75	0,86	33	3,0	180 x 355	25 x 35	30,0
	6 / 8	≥ 22	≥ 8	81	74	0,84	33	3,0	180 x 355	25 x 35	35,0
	6 / 10	≥ 24	≥ 8	80	71	0,82	35	3,0	180 x 355	25 x 35	40,0
<b>INTERFLAM EW</b>	6 / 6	≥ 20	≥ 8	75	72	0,82	33	1,8	180 x 355	25 x 35	30,0

All technical rights reserved

#### CE-Marking:

All INTERFLAM<sup>®</sup> and INTERFIRE<sup>®</sup> glasses are CE-certified by cticm / Notified Body 1166.

## 5 Description of INTERPANE Products



### INTERVER delivery programme for INTERFLAM<sup>®</sup> EW and INTERFIRE<sup>®</sup> EI fire-resistant and safety glazing with functional layers for thermal insulation

#### Basic Standards:

Fire tests in accordance with national norms and EN Standard EN 1363/1364 as well as certificates according EN 13501-2. Detailed information about tested sizes and frames systems in each country are available on our actual element overview.

	Thickness of glass (mm)	Thickness of element (mm)	Interlayer (mm)	Spacer (mm)	Lightransmission in %	G-Value in %	Soundreduction in dB	U-Value in W/m <sup>2</sup> K	max. size of production in cm	min. size of production in cm	weight in kg/m <sup>2</sup>
<b>Single compound</b>											
<b>INTERFLAM EW 30/10</b>	4 / 4	10	2	–	88	74	35	5,8	200 x 300	25 x 35	23,0
<b>INTERFLAM EW 120/13</b>	5 / 5	13	3	–	88	74	37	5,8	200 x 300	25 x 35	29,0
<b>INTERFLAM A0</b>	5 / 5	13	3	–	88	74	37	5,8	200 x 300	25 x 35	29,0
<b>INTERFIRE EI 30/16</b>	5 / 5	16	6	–	87	73	38	5,0	200 x 300	25 x 35	34,0
<b>INTERFIRE EI 60/24</b>	5 / 4 / 5	24	5	–	86	69	42	5,0	150 x 280	25 x 35	52,0
<b>INTERFIRE A60</b>	5 / 5 / 5	25	5	–	86	69	42	5,0	150 x 280	25 x 35	54,5
<b>INTERFIRE EI 90/32</b>	5 / 8 / 5	33	7	–	82	63	43	5,0	150 x 250	25 x 35	68,0
<b>INTERFIRE EI 120/47</b>	5 / 8 / 8 / 5	47	7	–	76	57	46	5,0	150 x 250	25 x 35	98,0
<b>Sealed units</b>											
<b>INTERFLAM EW 120/13</b>	5 / 5 / 6	31	3	12	77	62	38	1,3	200 x 300	25 x 35	43,0
<b>INTERFIRE EI 30/16-2</b>	5 / 5 / 6	34	6	12	76	61	39	1,3	200 x 300	25 x 35	47,0
<b>INTERFIRE EI 60/15-3</b>	5 / 4 / 5 / 6	42	5	12	75	57	43	1,3	150 x 280	25 x 35	65,0
<b>INTERFIRE EI 90/32</b>	5 / 8 / 5 / 6	51	7	12	73	51	47	1,3	150 x 250	25 x 35	82,0

All technical rights reserved

#### CE-Marking:

All INTERFLAM<sup>®</sup> and INTERFIRE<sup>®</sup> glasses are CE-certified by cticm / Notified Body 1166.



 **INTERPANE**  
*GLASS FOR LIFE*

INTERPANE designer glazing for harmonious renovation of historic buildings and distinctive new construction: aesthetically pleasing forms combined with modern functionality.



### 5.12 Insulating glazing as a functional design element

The building constructor, the public curator of historic buildings, the town planner, the building authority and the planning architect all determine the external appearance of a building and thus also the design of windows and glazing.

When an old building is to be renovated, often the requirements on historic buildings and

town planning demand that a façade be retained or be replaced by a reconstruction which imitates the original as closely as possible.

Apart from this aspect, a building constructor often wishes to set special accents in a new building by including particular design features.

Insulating glazing, with its diverse design options, offers planners and building constructors a wide field for exercising creativity:

- shaped glass
- glazing bar design
- patterned glass

## 5 Description of INTERPANE Products



### 5.12.1 Shaped glass

A great range of different shaped glass can be produced with modern production methods.

This means that the possibilities for individually designed glass architecture are almost unlimited.

The illustrations overleaf indicate the dimensions which must be specified for production. If glazing units are ordered with different glass types or pane thicknesses, the drawings must always include a specification of the type of glass facing the viewer.

In drawings of custom-shaped insulating glass units including iplus E low-e panes, ipasol solar-control panes, iplus E/ipaphon sound-insulation panes or special glass, it is equally essential to specify the coated surface.

Customised shapes with re-entrant angles (e.g. models 55 and 56) must be made of thermally toughened glass.

The delivery possibilities for all other customised shapes which are not illustrated in the catalogue must be agreed upon in advance before ordering.

The templates needed for production must be made of single sheets of flat plywood or hard-board in 1:1 scale. The templates must not be thicker than 5 mm.

Only the template dimensions are definitive for production.

For the variants illustrated on the following pages, no templates are needed if the required dimensions are specified accurately.

## 5 Description of INTERPANE Products



### Catalogue of shaped glass

<p>1 oblique edge</p>	<p>1 oblique edge</p>	<p>polygon</p>	<p>polygon</p>	<p>trapezium</p>
<p>trapezium</p>	<p>polygon</p>	<p>polygon</p>	<p>polygon</p>	<p>polygon</p>
<p>polygon</p>	<p>polygon</p>	<p>polygon</p>	<p>polygon</p>	<p>polygon</p>
<p>polygon</p>	<p>polygon</p>	<p>polygon</p>	<p>equilateral triangle</p>	<p>polygon</p>
<p>triangle</p>	<p>triangle</p>	<p>polygon</p>	<p>polygon</p>	<p>polygon</p>
<p>polygon</p>	<p>triangle</p>	<p>Delivery possibilities for shapes not included in this catalogue on request</p>	<p>triangle</p>	<p>triangle</p>

## 5 Description of INTERPANE Products

### Catalogue of shaped glass

 triangle	 oblique trapezium	 oblique trapezium	 polygon	 polygon
 rectangle plus parallelogram	 rectangle plus parallelogram	 parallelogram	 parallelogram	 circle with diameter D*
 circle with radius R*	 semicircle (circle segment)	 circle segment with radius R	 circle segment with segment height H1	 circle segment with radius R
 circle segment with radius R	 circle segment with arc height H2	 circle segment with arc height H2	 circle sector with radius R	 circle sector with radius R
 circle sector with arc height H1	 circle sector with arc height H1	 circle sector with arc height H1	 radii at least 10 cm 2 rounded corners	 radii at least 10 cm 4 rounded corners
 semicircle (2 x R = B)	 polygon	 polygon	 circle sector with radius R	 rhombus

1) thermally toughened glass

\*)  $\phi$  at least 45 cm for monolithic laminated safety glass  
 $\phi$  at least 30 cm for monolithic thermally toughened glass  
 For insulating glass units:  
 min.  $\phi$  = 30 cm  
 max.  $\phi$  = 150 cm

### 5.12.2 Glazing bars

The problems associated with small insulating glass units are known: the air or gas which is sealed into the space between the panes expands and contracts frequently during the lifetime of the unit, creating a load due to the resulting pumping movement. If the external air pressure falls (with respect to that at the time of production), the panes become convex. If the air pressure rises, the panes deform concavely.

This (physically caused) effect does not usually cause problems, as the modern sealants used in high-quality insulating glass units and the limited elasticity of the glass can accommodate this phenomenon. However, the smaller the insulating glass unit, the more the glass panes act as stiff, inelastic plates. This means that the entire stress resulting from the pumping movement is applied to the edge seal. Under certain circumstances, this can shorten the lifetime of the insulating glass unit.

For this reason, modern glazing bar systems for insulating glass units such as the "Swiss Cross" and "Viennese glazing bar" are preferable to constructions with small-area insulating glass units.

Effect of glazing bars on

sound insulation

Windows with glazing bars have always been considered critical with respect to sound insulation. Genuine glazing bars bring the risk that sound will be transmitted significantly through cracks in the glazing bar joints. For this reason, a correction factor (KSp) for glass-dividing glazing bars should be taken into account in accordance with DIN 4109, Appendix 1/A1.

When glazing bars are mounted within the space of insulating glass units, the sound-insulating effect can be reduced. However, the impact sound conduction (EN 717) through the glazing bars in an insulating glass unit can be eliminated if the glazing bar element in the gap does not have direct contact with the panes.

This condition is met, for example, by insulating glass units produced by INTERPANE with the "Swiss Cross" and the "Viennese glazing bar". See also the investigation by E. Sälzer published in "Bauphysik 6/85".

There are additional positive effects for the "Swiss Cross" due to

- the mass increase due to the glazing bar profiles used and

for the "Viennese glazing bar" due to

- the mass increase due to the spacers used
- the mass increase due externally applied glazing bars and
- the external attenuation resulting from the bars adhering to the panes.

If glass with high absorptance or asymmetric glass thicknesses are used, the permissibility of the combination must be tested in advance.

Effect of glazing bars on thermal insulation

Additional heat fluxes occur near internally mounted or externally applied glazing bars which must be taken into account when the U values for the window are calculated.

Significant parameters include:

- number of glazing bars
- material of the glazing bars
- width of the glazing bars
- distance of the glazing bars from the glass surface
- emissivity of the glass surface
- gas fill

The effects can be described by the additional linear thermal bridge term  $\psi$ .

DIN V 4108 requires that the effect of glazing bars be taken into account by the correction factor  $\Delta U_g$  when the  $U_{g,BW}$  value is determined (see Section 3.3.2).

## 5 Description of INTERPANE Products

### INTERPANE insulating glass units with "Viennese glazing bars"

This glazing bar system gives the appearance of a conventionally produced, double-glazed window with genuine glazing bars.

The window frame is filled with one complete insulating glass unit. External glazing bars are fixed subsequently to the surface of the pane during installation of the window. The internal spacer bars behind the glazing bars do not contact the glass surfaces directly. With a gap of usually 3 mm between the glass and the spacer bars, the mechanical behaviour of the insulating glass unit corresponds to that of large-area glazing.

Please note Section 6.4.12 in INTERPANE's Glazing Guidelines.

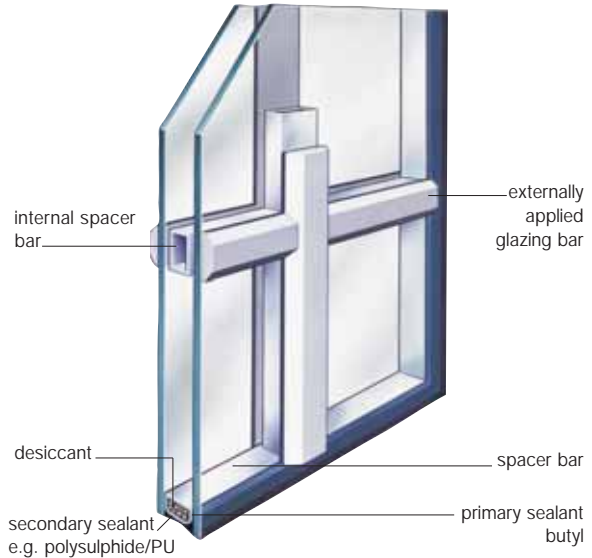

Cross-section through an insulating glass unit with "Viennese glazing bars"

Delivery programme for INTERPANE insulating glass units with "Viennese glazing bars"			
configuration		4/16/4	5/16/6
max. dimensions (cm)		141 x 240	245/300
max. area (m <sup>2</sup> )		3.40	6.00
max. ratio of side lengths		1:6	1:6
Visible width of spacer bar (combinations also possible)			
	20 mm	24 mm	30 mm
Please note that the external glazing bars (always somewhat wider than the internal spacer bars) are applied by the window installer.			
The colour of the internal spacer bar is matched to that of the regular spacer bars for the insulating glass unit.			

## 5 Description of INTERPANE Products



INTERPANE insulating glass units with "Swiss Cross" glazing bars

The glazing bars are mounted within the gap between the panes and do not contact the glass surfaces directly.

The "Swiss Cross" consists of extruded aluminium bars and is produced in various widths and colours.

The joints between the glazing bars look like those of genuine wooden glazing bars made by a carpenter, and guarantee that the cross maintains its shape durably.

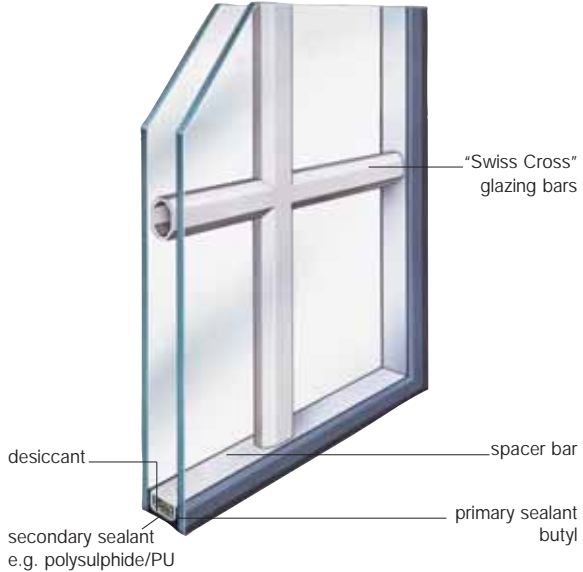

Cross-section through an insulating glass unit with "Swiss Cross" glazing bars

Delivery programme for INTERPANE insulating glass units with "Swiss Cross" glazing bars			
configuration	4/16/4*	5/16/6*	
max. dimensions (cm)	141 x 240	245 / 300	
max. area (m <sup>2</sup> )	3.40	6.00	
max. ratio of side lengths	1:6	1:6	
Standard "Swiss Cross" model			
glazing bar widths	18 mm	26 mm	45 mm
Different glazing bar widths can also be combined with each other. The 66 mm glazing bar can be delivered only in white.			
Glazing bar 2000 "Swiss Cross" model			
glazing bar widths	18 mm	26 mm	45 mm
Glazing bars with widths 18 mm + 26 mm, and 26 mm + 45 mm, can be combined.			
* Production with a gap width of 14 mm is possible.			

The glazing bars in INTERPANE insulating glass units can be delivered in many different colours and wood effects.  
Two-colour combinations are also possible.

## 5 Description of INTERPANE Products

INTERPANE  
insulating glass units with  
"Filigree" glazing bars

A charming variation of the "Swiss Cross" is presented by filigree internally mounted glazing bars. The fine glazing bars, with a cross-section of only 8 mm x 10 mm, add a decorative accent particularly to exclusive architecture with distinctive window shapes. They closely resemble genuine hand-crafted glazing.

Just as with the "Swiss Cross", the glazing bars are mounted internally in the gap between the panes without direct contact to the glass surface, and are thus protected against weathering. This configuration also makes the panes particularly easy to clean.

Rectangular patterns can be produced according to the customer's wishes, as long as the area of the largest rectangle does not exceed 70 cm x 70 cm.

Different filigree glazing bars are offered according to the demands of each regional market. Ask your supplier about the possibilities.

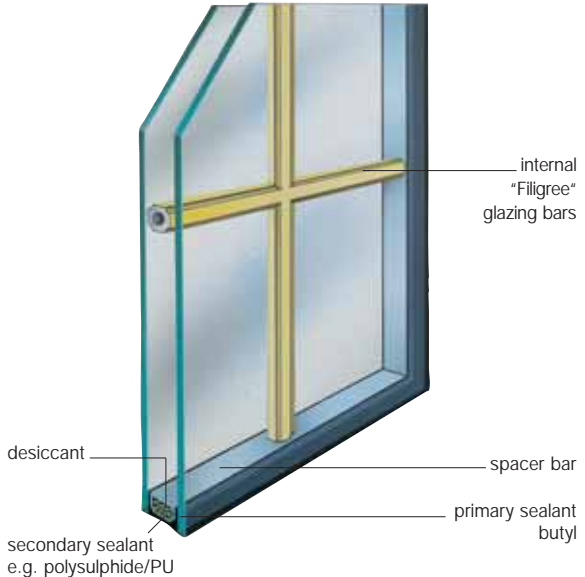

Cross-section through an insulating glass unit with "Filigree" glazing bars

<b>Delivery programme for INTERPANE insulating glass units with "Filigree" glazing bars</b>		
configuration	4/16/4*	5/16/6*
max. dimensions (cm)	141 x 240	245/300
max. area (m <sup>2</sup> )	3.40	6.00
max. ratio of side lengths	1:6	1:6
* Production with a gap width of 14 mm is possible.		
max. single rectangle dimensions (cm <sup>2</sup> )	70 x 70	
glazing bar divisions	only rectangular	
glazing bar cross-section (mm <sup>2</sup> )	8 x 10, viewing width 10 mm	
standard anodised colours	gleaming gold, lead-coloured, polished brass	
standard colour	white, polymer-coated	
<b>anodised glazing bar, oval cross-section, gleaming gold</b>	cross-section 6 mm x 8 mm, viewing width 8 mm	

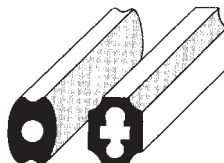

type 1    type 2

### 5.12.3 Insulating glazing combined with patterned glass

Patterned glass is a form of cast glass which gains a certain surface structure on passing through rollers. Visibility through such glass is limited.

Patterned glass is used where visibility is unnecessary or undesirable, and where it can be applied as a design element.

The patterns chosen for cast glass vary with fashion over time. Distinctions are made between:

- translucent and coloured patterned glass
- translucent cast glass without patterns
- translucent and coloured wired glass
- translucent and coloured patterned, wired glass.

Almost all types of commercially available patterned glass can be processed to form insulating glass units (see Table 5.12.4).

- In general, the patterned surface is positioned toward the gap between the panes. It is possible that the sealant then becomes visible around the edges of the gap.

In combinations of cast glass, the approximately 12 mm depth of the edge seal can be exceeded by up to 3 mm in some positions.

We draw your attention to the fact that the special properties of this type of glass make it more prone to breakage.

- In asymmetric combinations of pane thicknesses (e.g. for sound insulation), if a float glass pane is to be replaced by cast glass, this pane must be at least as thick as the replaced float glass pane.
- When wired glass is used for one pane of an insulating glass unit, the other pane must always be thinner or at most equally thick. The differ-

ence in thickness between a cast glass pane without wiring and the opposing pane may not exceed 4 mm. This should be noted particularly for sound insulation combinations with specified configurations.

- When coloured cast glass or wired cast glass is exposed to solar radiation, it may heat up inhomogeneously, particularly if the glass is partly shaded. If such panes are part of an insulating glass unit, the danger of breakage due to thermal stress is increased. In these cases, thermally toughened glass or heat-strengthened glass should be used; the supplier is obliged to inform the final customer of this situation.
- If coloured cast glass is combined with coated glass (low-e or solar-control coatings), the cast glass pane should be tempered (thermally toughened or heat-strengthened glass).

### 5.12.4 Patterned glass combinations

pattern	colour	thickness (mm)	insulating glass panes		max. ratio of side lengths for 12 mm gap	max. dimensions cm <sup>2</sup>
			structure orientation	surface		
Bamboo	translucent	5	△	X	1 : 10	161 x 213
Barock	translucent	4	△	X	1 : 6	165 x 210
Barock	bronze	4	△	X	1 : 6	165 x 210
Cast antique	translucent	4	X	X	1 : 6	150 x 210
Cast antique 103	yellow	4	X	X	1 : 6	150 x 210
Cathedral hammered small	translucent	4	X	X	1 : 6	150 x 210
Chinchilla	translucent	4	△	X	1 : 6	156 x 213
Chinchilla	bronze	4	△	X	1 : 6	156 x 213
Delta	translucent	4	X	X	1 : 6	156 x 213
Delta	bronze	4	X	X	1 : 6	156 x 213
Delta	matt translucent	4	X	X	1 : 6	156 x 213
Edelit double-sided	translucent	4	△	X	1 : 6	150 x 210
Gothic	translucent	4	△	X	1 : 6	156 x 213
Gothic	bronze	4	△	X	1 : 6	156 x 213
Ice flower glass	translucent	4	X	X	1 : 6	150 x 240
Listral SR 200	translucent	6	△	X	1 : 10	200 x 321
Listral SR 200	translucent	8	△	X	1 : 10	200 x 321
Madras Uadi	translucent	5	△	X	1 : 10	180 x 321
Madras Pave	translucent	5	X	X	1 : 10	180 x 321
Mastercarre	translucent	4	△	X	1 : 6	200 x 321
Masterligne	translucent	4	△	X	1 : 6	200 x 321
Masterlens	translucent	4	△	X	1 : 6	200 x 321
Masterpoint	translucent	4	X	X	1 : 6	200 x 321
Masterray	translucent	4	△	X	1 : 6	200 x 321
<p><b>Legend:</b> □ = structure orientation can not be taken into account            △ = structure orientation running parallel to height            X = structure orientation optional, structured side optional</p>						

## 5 Description of INTERPANE Products



### 5.12.4 Patterned glass combinations

pattern	colour	thickness (mm)	insulating glass panes		max. ratio of side lengths for 12 mm gap	max. dimensions cm <sup>2</sup>
			structure orientation	structure surface		
Neolit	translucent	4	X	X	1 : 6	150 x 210
Niagara	translucent	5	△	X	1 : 10	156 x 213
Niagara	bronze	5	△	X	1 : 10	156 x 213
Niagara matt blank	translucent	5	△	X	1 : 10	156 x 213
Old German K – short edge ≥ 25 cm ⊙	translucent	4	△	X	1 : 6	150 x 210
Old German K – short edge ≥ 25 cm ⊙	bronze	4	△	X	1 : 6	150 x 210
Pattern 176 (Madera)	translucent	4	△	X	1 : 6	150 x 210
Pattern 176 (Madera)	bronze	4	△	X	1 : 6	150 x 210
Pattern 178 (Silvit)	translucent	4	△	X	1 : 6	150 x 210
Pattern 178 (Silvit)	bronze	4	△	X	1 : 6	150 x 210
Pattern 187 (Abstracto)	translucent	4	□	X	1 : 6	150 x 210
Pattern 187 (Abstracto)	bronze	4	□	X	1 : 6	150 x 210
Pattern 504	translucent	4	X	X	1 : 6	150 x 210
Pattern 521	translucent	4	X	X	1 : 6	150 x 210
Pattern 523	translucent	4	X	X	1 : 6	150 x 210
Pattern 528	translucent	4	X	X	1 : 6	150 x 210
Pattern 550	translucent	4	X	X	1 : 6	150 x 210
Pattern 597	translucent	4	X	X	1 : 6	150 x 210
Satinato	translucent	4	X	X	1 : 6	225 x 321
Satinato	translucent	6	X	X	1 : 10	225 x 321
Silk	translucent	4	△	X	1 : 6	165 x 210
Wired glass with grid	translucent	7	X	X	1 : 10	186 x 300
Wired pattern 187 (Abstracto)	translucent	7	□	X	1 : 10	180 x 245
Wired pattern 523	translucent	7	X	X	1 : 10	180 x 245

All other types of patterned glass on request.

**Legend:** □ = structure orientation can not be taken into account  
 △ = structure orientation running parallel to height  
 X = structure orientation optional, structured side optional

⊙ The specific physical properties of this type of patterned glass should be observed when it is used to make insulating glass units. We thus recommend that an area of 1.5 m<sup>2</sup> should not be exceeded.